

SDWS — Timber Screw

Material: Carbon Steel

Finish: Double Barrier Coating
(Suitable for interior, treated timber and external applications)



Size: See table below

Features & Benefits

- 6-lobe, T-40 drive eliminates cam outs, for easier installations and longer bit life — bit(s) included
- Head stamped for easy identification of length and diameter, for building certification
- Large Washer Head provides superior clamping, while nibs offer greater control for the installer when seating the head
- Bold Threads design provides superior holding power, even into the end grain of timber
- Patented SawTooth™ Point for faster starts, less torque and no pre-drilling

Application

- Outdoor Structures
- Deck Frames and Ledgers
- Landscaping
- Structural Timber Framing — It replaces strapping, which means, no interference with wall cladding

Construction Details



6-lobe, T-40 drive eliminates cam-outs, for easier installations and longer bit life. **Head Stamped** for easy identification of length and diameter, for building certification.



Large **Washer Head** provides superior clamping, while nibs offer greater control for the installer when seating the head



Patented **SawTooth™ Point** for faster starts, less torque and no pre-drilling

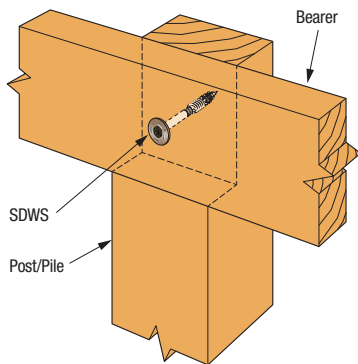

SDWS Bearer-to-Post/Pile Connection

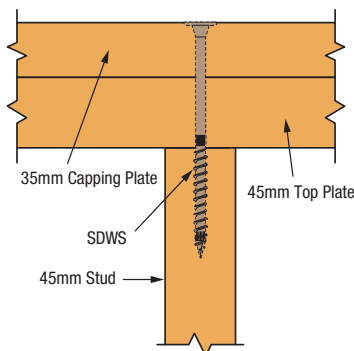

SDWS Stud-to-Top Plate Cross Section

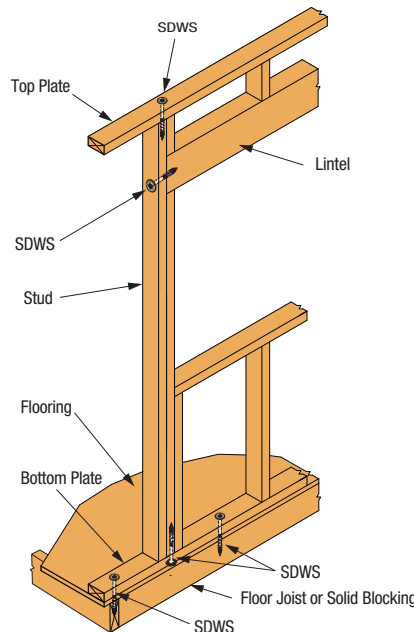

SDWS Top/Bottom Plate-to-Stud Stud-to-Lintel Bottom Plate-to-Joist Connection

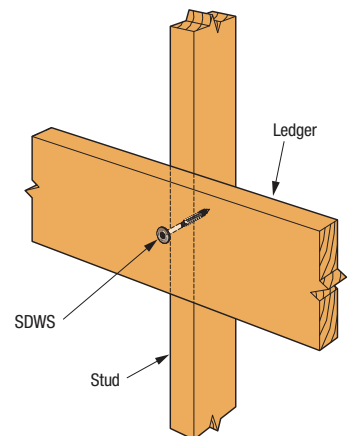

SDWS Ledger-to-Stud Connection

SDWS – Timber Screw

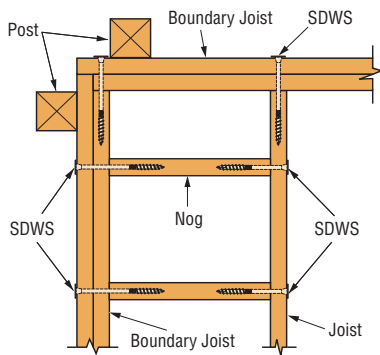

SDWS Deck Joist Fixing - Plan View

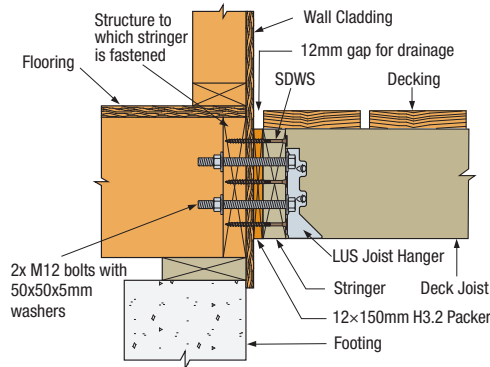

SDWS Stringer-to-House for Deck Connection

SDWS Technical Data

Table 1. Strong-Drive® SDWS Timber Screw Specifications

Model	Head Marking (##)	Screw Length (mm)	Thread Length ^{1,2} (mm)	Diameter (mm)			Fastener Strength			
				Shank	Major	Minor	Bending Yield Strength ³ (Mpa)	Characteristic Yield Moment ⁴ (kNmm)	Tension ⁵ (kN)	Shear ⁵ (kN)
SDWS22300DB	3	76	38	5.6	7.7	5.0	1103	17.9	10.5	6.1
SDWS22400DB	4	102	60							
SDWS22500DB	5	127	70				1207			
SDWS22600DB	6	152								
SDWS22800DB	8	203								
SDWS221000DB	10	254								

- For the purpose of measuring overall length, fasteners shall be measured from the underside of the head to bottom of the point.
- Length of thread includes the point.
- Bending yield strength determined following ASTM F1575 and based on minor thread diameter.
- Characteristic yield moment determined following EU14358 and based on minor thread diameter.
- Tension and shear properties are based on 0.5 of the average maximum load for screws tested in tension and shear, respectively. Shear strength is shear through the threads.

Table 2. Strong-Drive® SDWS Timber Screw Limit States-Reference Characteristic Load Values (N) for Timber-to-Timber Connections^{1,2,3,4,5}

Model	Screw Length (mm)	Timber Joint Group	Characteristic Shear Loads (N)									Characteristic Withdrawal Capacity (N/mm)		
			Timber Side Member Thickness									Face Grain	End Grain	
			35	45	63	70	90	100	115	150	200			
SDWS22300DB	76	JD4	6630	—	—	—	—	—	—	—	—	—	88	62
		JD5	4995	—	—	—	—	—	—	—	—	—	82	50
		JD6	3896	—	—	—	—	—	—	—	—	—	64	40
SDWS22400DB	102	JD4	7400	6100	6100	—	—	—	—	—	—	—	112	69
		JD5	6000	6000	4545	—	—	—	—	—	—	—	91	54
		JD6	4680	4680	3545	—	—	—	—	—	—	—	71	42
SDWS22500DB	127	JD4	7400	7400	6100	5655	5655	—	—	—	—	—	134	110
		JD5	6000	6000	6000	3920	3920	—	—	—	—	—	93	78
		JD6	4680	4680	4680	3058	3058	—	—	—	—	—	73	60
SDWS22600DB	152	JD4	7550	7550	7550	7550	5865	5865	5840	—	—	—	134	110
		JD5	6030	6030	6030	6030	5220	5220	4385	—	—	—	93	78
		JD6	4703	4703	4703	4703	4072	4072	3420	—	—	—	73	60
SDWS22800DB	203	JD4	8055	8055	8055	8055	7040	7040	7040	6100	—	—	134	110
		JD5	6240	6240	6240	6240	5500	5500	5500	5485	—	—	93	78
		JD6	4867	4867	4867	4867	4290	4290	4290	4278	—	—	73	60
SDWS221000DB	254	JD4	8055	8055	8055	8055	7040	7040	7040	7040	6100	—	134	110
		JD5	6240	6240	6240	6240	5500	5500	5500	5500	5500	—	93	78
		JD6	4867	4867	4867	4867	4290	4290	4290	4290	4290	—	73	60

- Conditions without numbers in the matrix shall not be used.
- The main and side members shall have a minimum density of 530 kg/m³ for JD4, 450 kg/m³ for JD5 or 400 kg/m³ for JD6.
- The tabulated characteristic shear loads and withdrawal are for normal duration of load.
- Screws shall be installed straight into the side grain of the wood main member with the screw axis at a 90-degree angle to the wood fibres.
- Minimum fastener penetration shall be equal to the screw length less the thickness of the wood side member.
- Tabulated characteristic values for withdrawal are in N/mm of thread length into the main member
- Withdrawal to end grain values are based on the lesser value of withdrawal from the main member or the characteristic pull-through of the screw through a 35 mm thick side member of the same Joint Group, or tensile strength of the screw.