

Hole Preparation — Vertical Applications

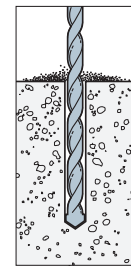

1. Drill.
Drill a 19 mm-diameter hole for a 16 mm-diameter anchor rod. Embedment depth is per the building plan.

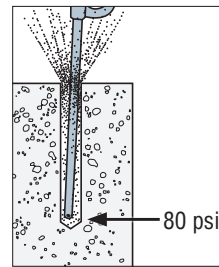

2. Blow.
Remove dust from hole with oil-free compressed air for a minimum of four seconds (SET-XP). Compressed air nozzle must reach the bottom of the hole.

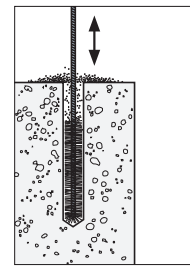

3. Brush.
For SET-XP, clean with a steel brush for a minimum of four cycles. Brush should provide resistance to insertion. If no resistance is felt, the brush is worn and must be replaced.

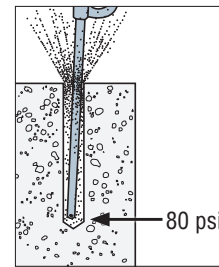

4. Blow.
Remove dust from hole with oil-free compressed air for a minimum of four seconds (SET-XP). Compressed air nozzle must reach the bottom of the hole.

Visit strongtie.com for proper brush part number.

Anchor Height Above Concrete

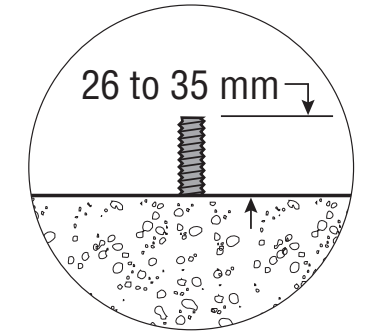

PFS9 ANCHOR TEMPLATE

(use to mark the location of the anchor bolts)

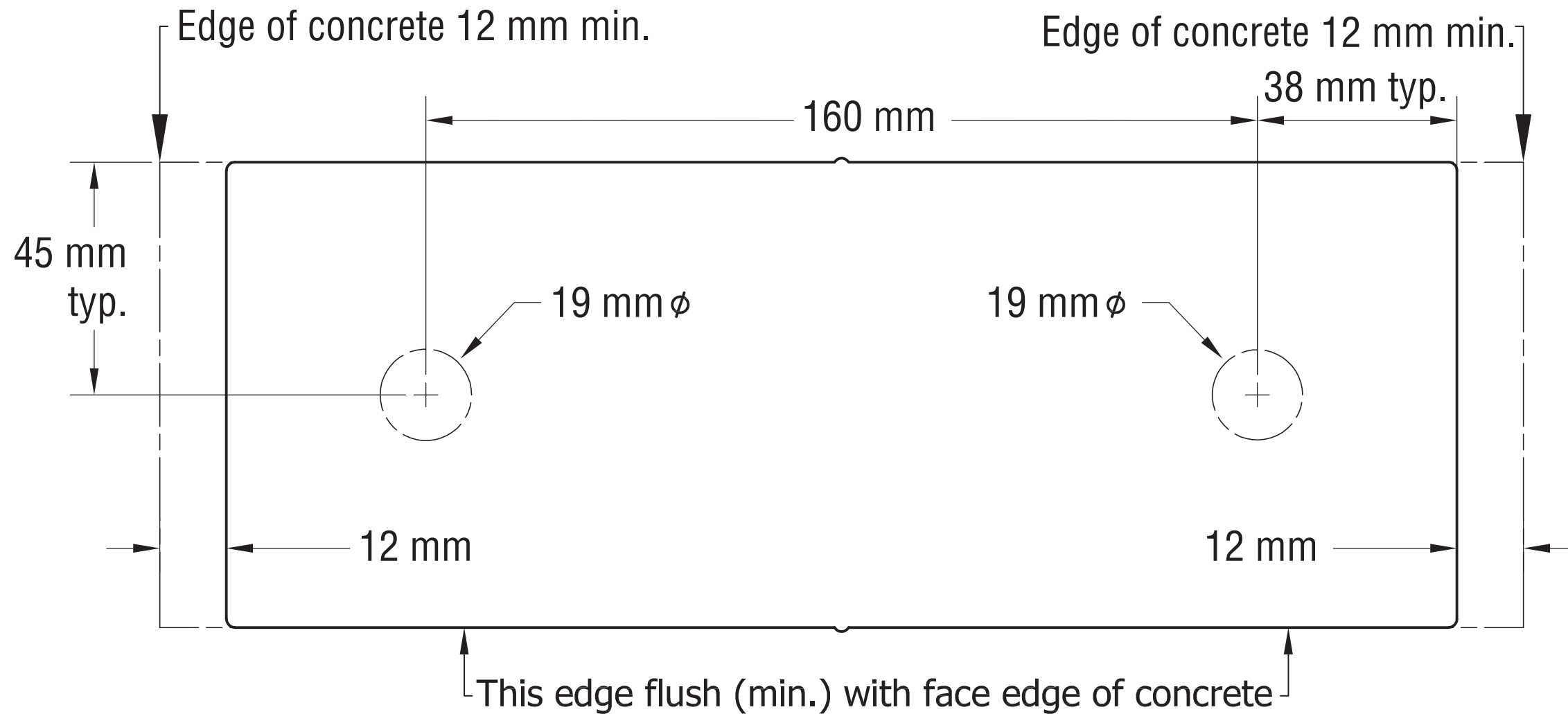

Anchor Height Above Concrete

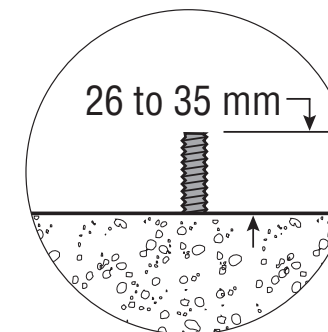

3. Do not disturb.
 Remove excess adhesive around anchor. Do not disturb anchor until fully cured. (See cure schedule for specific adhesive.)

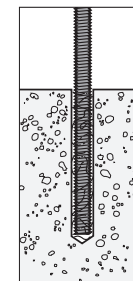

2. Insert.
 Insert clean, oil-free anchor, turning slowly until the anchor contacts the bottom of the hole.
Threaded rod

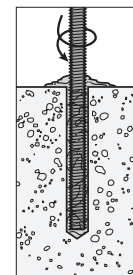

1. Fill.
 Fill hole 1/2 to 3/4 full, starting from bottom of hole to prevent air pockets. Withdraw nozzle as hole fills up.

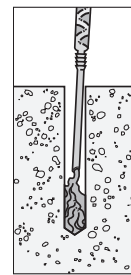

Filling the Hole — Vertical Anchorage

Prepare the hole per "Hole Preparation" instructions on product label.

Dry and Damp Holes:

Refer to strongtie.com for proper mixing nozzle and dispensing tool part number.

Note: Refer to T-L-PFSHWAUZ19 for PFS framing instructions. Reference building plans for anchorage and embedment depth. Additional anchorage information can be found at strongtie.com/au.

Cartridge Preparation

1. Check.

Check expiration date on product label. **Do not use expired product.** Product is usable until end of printed expiration month.

2. Open.

Open cartridge per package instructions.

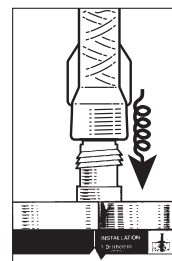

3. Attach.

Attach proper Simpson Strong-Tie® nozzle and extension to cartridge. Do not modify nozzle.

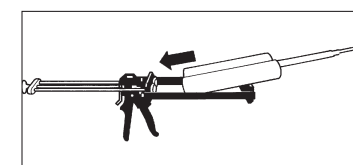

4. Insert.

Insert cartridge into dispensing tool.

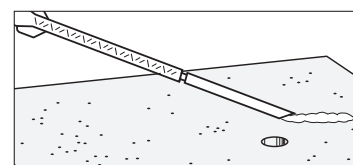

5. Dispense.

Dispense adhesive to the side until properly mixed (uniform color).

Refer to strongtie.com for proper mixing nozzle and dispensing tool part number.

Note: Refer to T-L-PFSHWAUZ19 for PFS framing instructions. Reference building plans for anchorage and embedment depth. Additional anchorage information can be found at strongtie.com/au.

PFS12 ANCHOR TEMPLATE

(use to mark the location of the anchor bolts)

