

# Quik Drive® Project Pro™ Screw Driving Tool



Decking



Subfloor



Wall Lining



Fencing

Fasten projects up to 4X faster!

**Introducing an exciting new way to complete your projects. The Simpson Strong-Tie® Project Pro screw driving tool provides a versatile solution that makes fastening faster, safer and easier.**

## Features & Benefits

- Auto-feed technology drives screws repeatedly – just point and drive.
- Fits most cordless drills or impact drivers.
- Simple to use – less experienced users can work quickly and efficiently.
- No fumbling and dropping screws.
- Project Pro™ is compatible with industry-leading Quik Drive® premium collated fasteners.

**Fasten projects up to 4X faster!\***



Scan for more info



Works with most cordless drill or driver motors

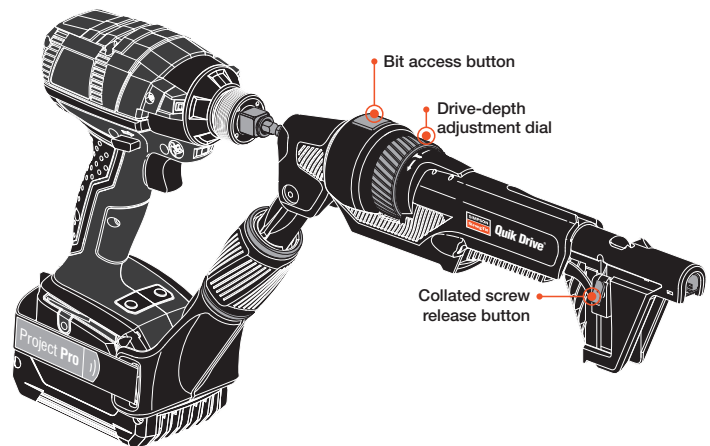
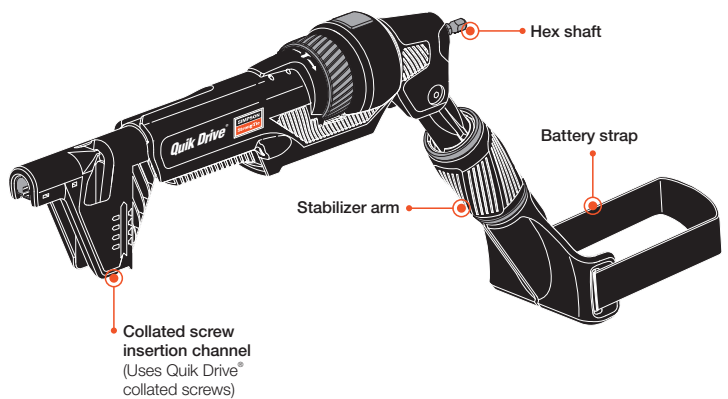

Simpson Strong-Tie® Australia  
Call 1300 STRONGTIE (1300 787 664)  
www.strongtie.com.au

**Simpson Strong-Tie Limited Warranty:** For the Limited Warranty that applies to Simpson Strong-Tie products, please consult [www.strongtie.com.au/warranty](http://www.strongtie.com.au/warranty) or [www.strongtie.co.nz/warranty](http://www.strongtie.co.nz/warranty). To obtain a copy of the Limited Warranty, contact us at [info.au@strongtie.com](mailto:info.au@strongtie.com) or [info.nz@strongtie.com](mailto:info.nz@strongtie.com), or at the number provided here. The Limited Warranty contains important disclaimers, limitations and exclusions, and applies only if the products have been properly specified, installed, maintained, and used in accordance with the design limits and the structural, technical, and environmental specifications in the Simpson Strong-Tie Documentation. All future purchases of Simpson Strong-Tie products are subject to the terms of the Limited Warranty in effect as of the purchase date.



# Quik Drive Project Pro™

Screw Driving Tool



## Typical Installation

**STEP 1:** Attach the tool to your driver motor of choice. Insert into driver chuck and tighten.

**STEP 2:** Adjust length of stabiliser arm as needed. Affix strap around battery so that the strap is in line with battery. Tighten stabilizer arm.

**STEP 3:** Insert Quik Drive® collated fastener strip. Push "arrow point" end in first until it clicks in place.

**STEP 4:** Pull the trigger and then push down on the driver motor and tool until the screw head is seated. Test into scrap material to set the proper depth.

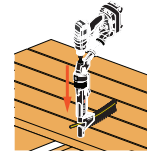
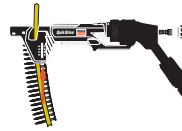
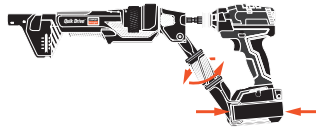
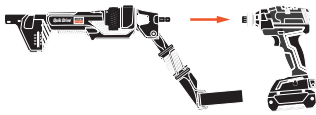

Note: Detailed instructions and troubleshooting steps are detailed in the Operator's Manual

## Product Information

Model No.	Retail Box Dim. (W x L x H) and weight	Individual Barcode	Carton Dim. (W x L x H) and weight	Carton Barcode	Carton Qty
QDPROJECTPROA	325 x 95 x 230mm, 1.2kg	707392026730	340 x 280 x 250mm, 4.1kg	10707392026737	3



(Retail Box)

### Retail Box Contents:

- Project Pro™ attachment
- T20 6-Lobe bit\*
- T25 6-Lobe bit\*
- SQ2 bit\*
- SQ2 Undersized bit\*
- PH2 bit\*
- Operator's Manual

\*All 200mm long



## Partner Product - Retail Pack Quik Drive® Screws

Model No.	Description
CBSDGL158SA*	10G x 42mm Steel Frame Screw CL3 Mech. Gal. #2SQU
WSV50SA*	10G x 50mm Timber Flooring Screw Yellow Zinc T25
DSVT2SA*	10G x 50mm Decking Screw Quik Guard® T25
DWCZ158PSA*	6G x 42mm Plasterboard Screw Yellow Zinc PH2
PPSD1050SA*	10G x 50mm Steel Frame Subfloor Screw Yellow Zinc T25
SSDHS50TSA*	12G x 50MM Hardwood Decking Screw 316SS T20
SSBFHSD2SA*	10G x 50mm Timber to Steel Decking Screw 316SS Bi-Metal SQ2

\*Available in Retail and Bulk packs

## Partner Products - Project Pro™ Replacement Bits

Model No.	Description	Card Dims. ea.mm/Box	Card Qty.	Box Qty.
BITPPTX20-ANZ	T20 6-Lobe x 200mm bit	Hang Card Dim. 45 (w) x 235 (h), 45g /	1	10
BITPPTX25-ANZ	T25 6-Lobe x 200mm bit			
BITPP2SU-ANZ	SQ2 Undersize x 200mm bit			
BITPP2S-ANZ	SQ2 x 200mm bit	Box of 10 Dim. 55 (w) x 245 (h) x 160 (l), 700g		
BITPP2P-ANZ	PH2 x 200mm bit			

Note: All screw packs include a standard Quik Drive® bit. Replacement ProjectPro™ bits can be purchased separately.



Retail Pack Quik Drive® Screws



Bulk Pack Quik Drive® Screws



Project Pro™ Driver Bit