

Together we're  
building safer, stronger  
structures.

**SIMPSON**

**Strong-Tie**

®



**Strong-Drive**<sup>®</sup>  
STRUCTURAL FASTENERS  
SDWS **TIMBER** Screw

The 2<sup>nd</sup> Generation with  
Patented **SawTooth™** point

*A structural screw with proven  
Performance, Versatility and Speed.*

# One Screw for Many Uses



The SDWS is the 2<sup>nd</sup> Generation, redesigned with a patented SawTooth™ point. It delivers faster starts, less torque, and eliminates the need for pre-drilling. All this reduces tool wear and extends your battery life!

No pre-drilling means more screws installed and less labour for you compared to conventional installation. The SDWS is the advanced alternative to bolting timber, or batten and coach screws, being 30% faster and 10% stronger than an equivalent batten screw.

## Application

Designed to be versatile the SDWS is recognised as a solution for engineered wood connections and is backed by testing and load data.

Applications include, but are not limited to:

- Outdoor Structures
- Deck Frames and Ledgers
- Landscaping
- Structural Timber Framing — It replaces strapping, which means, no interference with wall cladding.

## Finish

- Double Barrier Coating — Suitable for interior, treated timber and external applications.



Scan this QR code to watch a video of Strong-Drive® SDWS TIMBER Screw.  
<http://bit.ly/F-F-SDWS19>



## Features and Benefits



6-lobe T-40 drive **eliminates cam-outs**, for easier installations and longer bit life — bit(s) included.

Head stamped for **easy identification** of length and diameter, for building certification.



Large washer-head provides **superior clamping**, while nibs offer **greater control** for the installer when seating the head.



Bold thread design provides **superior holding power**, even into the end grain of timber.



Patented **SawTooth™ point** for faster starts, less torque and no pre-drilling.

## Product and Packaging Information

Model		Length (mm)		
Bulk Pack	Qty	50 Pack	Screw	Thread
SDWS22300DB	950	SDWS22300DB-R50	76	38
SDWS22400DB	600	SDWS22400DB-R50	102	60
SDWS22500DB		SDWS22500DB-R50	127	76
SDWS22600DB	500	SDWS22600DB-R50	152	
SDWS22800DB	400	SDWS22800DB-R50	203	
SDWS221000DB	250	SDWS221000DB-R50	254	



Bit(s) included. Replacement Bit: BIT40T-134-RC3

# Serious Screws for Structural Applications

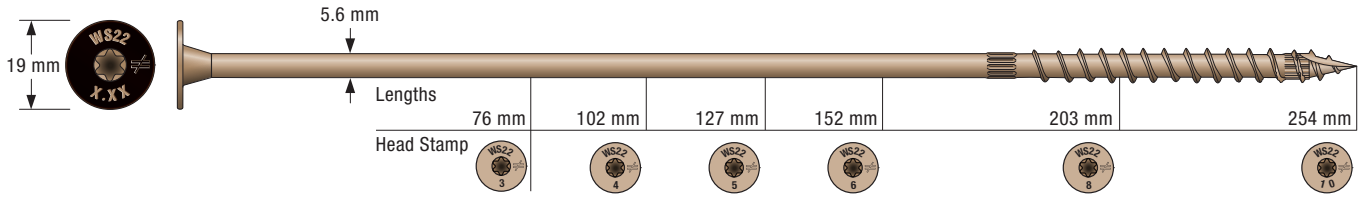

Table 1. Strong-Drive® SDWS Timber Screw Specifications

Model	Head Marking (#)	Screw Length (mm)	Thread Length <sup>1,2</sup> (mm)	Diameter (mm)			Fastener Strength			
				Shank	Major	Minor	Bending Yield Strength <sup>3</sup> (Mpa)	Characteristic Yield Moment <sup>4</sup> (kNm)	Tension <sup>5</sup> (kN)	Shear <sup>5</sup> (kN)
SDWS22300DB	3	76	38	5.6	8.0	5.0	1103	17.9	10.5	6.1
SDWS22400DB	4	102	60							
SDWS22500DB	5	127	76				1207			
SDWS22600DB	6	152								
SDWS22800DB	8	203								
SDWS221000DB	10	254								

- For the purpose of measuring overall length, fasteners shall be measured from the underside of the head to bottom of the point.
- Length of thread includes the point.
- Bending yield strength determined following ASTM F1575 and based on minor thread diameter.
- Characteristic yield moment determined following EU14358 and based on minor thread diameter.
- Tension and shear properties are based on 0.5 of the average maximum load for screws tested in tension and shear, respectively. Shear strength is shear through the threads.

Table 2. Australian Limit States-Reference Characteristic Lateral Load Values (N) for Timber-to-Timber Connections with SDWS Timber Screws<sup>1,2,3,4,5</sup>

Model	Screw Length (mm)	Timber Joint Group	Characteristic Shear Loads (N)									Characteristic Withdrawal Capacity (N/mm)		
			Timber Side Member Thickness									Face Grain	End Grain	
			35	45	63	70	90	100	115	150	200			
SDWS22300DB	76	JD4	6630	—	—	—	—	—	—	—	—	—	88	62
		JD5	4995	—	—	—	—	—	—	—	—	—	82	50
		JD6	3896	—	—	—	—	—	—	—	—	—	64	40
SDWS22400DB	102	JD4	7400	6100	6100	—	—	—	—	—	—	—	112	69
		JD5	6000	6000	4545	—	—	—	—	—	—	—	91	54
		JD6	4680	4680	3545	—	—	—	—	—	—	—	71	42
SDWS22500DB	127	JD4	7400	7400	6100	5655	5655	—	—	—	—	—	134	110
		JD5	6000	6000	6000	3920	3920	—	—	—	—	—	93	78
		JD6	4680	4680	4680	3058	3058	—	—	—	—	—	73	60
SDWS22600DB	152	JD4	7550	7550	7550	7550	5865	5865	5840	—	—	—	134	110
		JD5	6030	6030	6030	6030	5220	5220	4385	—	—	—	93	78
		JD6	4703	4703	4703	4703	4072	4072	3420	—	—	—	73	60
SDWS22800DB	203	JD4	8055	8055	8055	8055	7040	7040	7040	6100	—	—	134	110
		JD5	6240	6240	6240	6240	5500	5500	5500	5485	—	—	93	78
		JD6	4867	4867	4867	4867	4290	4290	4290	4278	—	—	73	60
SDWS221000DB	254	JD4	8055	8055	8055	8055	7040	7040	7040	7040	6100	—	134	110
		JD5	6240	6240	6240	6240	5500	5500	5500	5500	5500	—	93	78
		JD6	4867	4867	4867	4867	4290	4290	4290	4290	4290	—	73	60

- Conditions without numbers in the matrix shall not be used.
- The main and side members shall have a minimum density of 530 kg/m<sup>3</sup> for JD4, 450 kg/m<sup>3</sup> for JD5 or 400 kg/m<sup>3</sup> for JD6.
- The tabulated characteristic shear loads and withdrawal are for normal duration of load.
- Screws shall be installed straight into the side grain of the wood main member with the screw axis at a 90-degree angle to the wood fibres.
- Minimum fastener penetration shall be equal to the screw length less the thickness of the wood side member.
- Tabulated characteristic values for withdrawal are in N/mm of thread length into the main member
- Withdrawal to end grain values are based on the lesser value of withdrawal from the main member or the characteristic pull-through of the screw through a 35 mm thick side member of the same Joint Group, or tensile strength of the screw.

## Strong-Drive® SDWS Timber Spacing Requirements

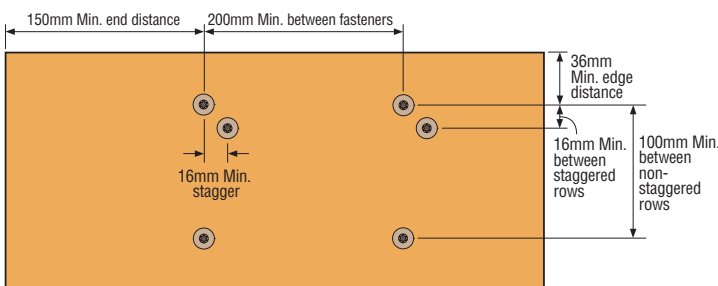

# One Screw for Many Uses

## A. Ledge Plate Shear Capacity

Model	Ledger plate size	Number of screws	Stud thickness	Characteristic capacity Qk (kN)
SDWS22400DB	90x45	1	35mm	3.8
SDWS22400DB	140x45	2	35mm	7.1

Note: All timber to be min JD5 joint group.

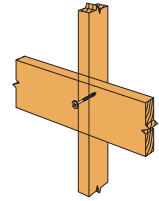

## B. Jamb Studs to Lintels

Model	Lintel Size	Number of screws each end of lintel	Jamb Stud	Characteristic capacity Qk (kN)
SDWS22500DB	2/140x35	4	70 x 35	10.7
SDWS22500DB	2/140x45	4	90 x 45	14.2
SDWS22600DB	2/190x35	6	2/70x35	16.3
SDWS22600DB	2/190x45	6	2/90x45	19.0

Note: All timber to be min JD4 joint group.

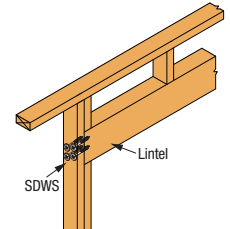

## C. Wall Plate-to-Stud Tie Down

Model	Screw Length (mm)	Wall Plate Thickness (mm)	Uplift Design Capacity (kN)		
			JD4	JD5	JD6
SDWS22400DB	102	35	3.5	2.8	2.2
		45	3.3	2.6	2.0
		70	1.9	1.5	1.1
SDWS22500DB	127	35	7.1	5.0	3.8
		45			
		70	5.3	3.8	2.9
		80	4.4	3.1	2.4
		90	3.5	2.5	1.8
SDWS22600DB	152	35	7.1	5.0	3.8
		45			
		70	6.7	4.7	3.6
		90	5.8	4.1	3.2

1. Refer to AS1684.2 or AS1684.3 Table 9.19 for typical comparison Tie-Down Connections.

## D. Bottom Plate-to-Joist Tie Down

Model	Screw Length (mm)	Wall Plate Thickness (mm)	Uplift Design Capacity (kN)		
			JD4	JD5	JD6
SDWS22300DB	76	35	1.6	1.5	1.2
SDWS22400DB	102	35	4.6	3.7	2.9
		45	3.6	2.9	2.3
SDWS22500DB	127	35	8.0	5.5	4.3
		45	7.2	5.0	3.9

1. Refer to AS1684.2 or AS1684.3 Table 9.18 for typical comparison Tie-Down Connections.  
 2. Uplift capacity allows for 19 mm flooring under bottom plate.

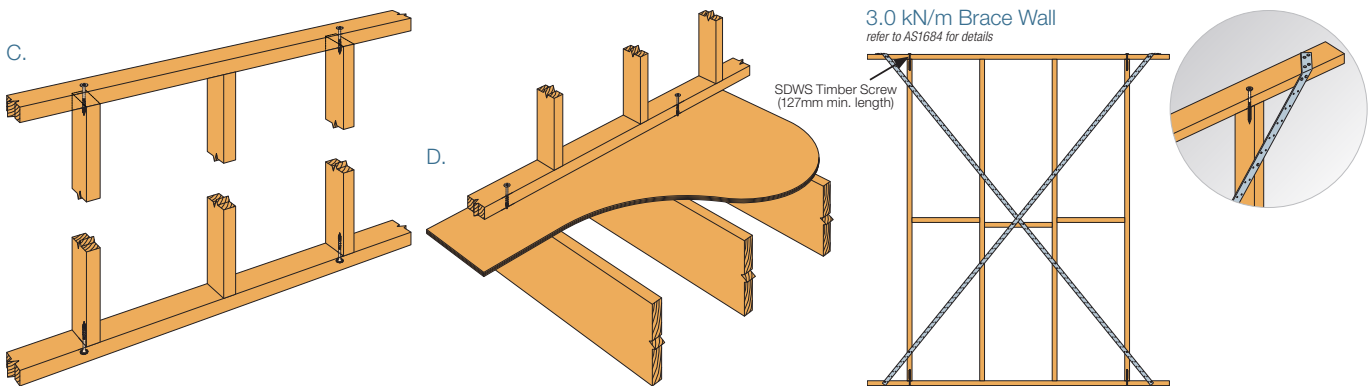

Generic Footnote: For Australia, the Capacity Factor ( $\phi$ ) is 0.85 for nails and screws for structural joints in a Category 1 application. Reduce tabulated values where other Category applications govern.