

SIMPSON

Strong-Tie

®

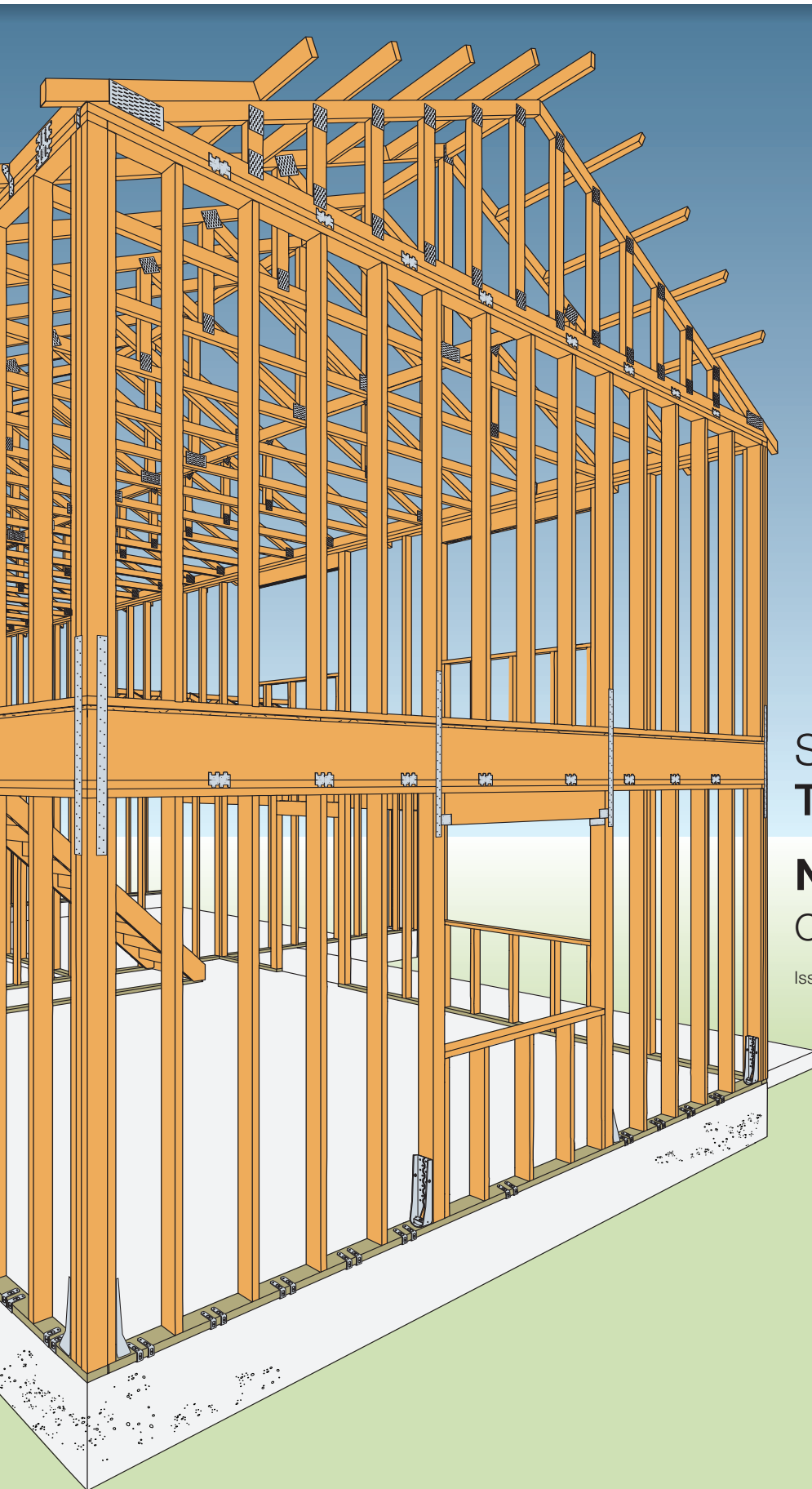

Simpson Strong-Tie® Timber Connectors

NZS 3604

Characteristic Capacities

Issued July 2024

Using Fasteners with Connectors

Connector Fastening Identification



Round Holes

Purpose: to fasten a connector.
Fill Requirements: always fill, unless noted otherwise.



Obround Holes

Purpose: to make fastening a connector in a tight location easier.
Fill Requirements: always fill.



Hexagonal Holes

Purpose: to fasten a connector to concrete or masonry.
Fill Requirements: always fill when fastening a connector to concrete or masonry.



Triangular Holes

Purpose: to increase a connector's strength or to achieve Max strength.
Fill Requirements: when the Designer specifies Max nailing.



Diamond Holes

Purpose: to temporarily fasten a connector to make installing it easier.
Fill Requirements: none.



IUSE Strong-Grip™

The Strong-Grip™ seat allows the I-joist to "snap" in securely without the need for joist nails.



Pilot Holes

Tooling holes for manufacturing purposes. No fasteners required.



Speed Prongs

Used to temporarily position and secure the connector for easier and faster installation.



Positive Angle Nailing (PAN)

Provided when timber splitting may occur, and to speed installation.



Dome Nailing

This feature guides the nail into the joist and header at a 45° angle.



Double-Shear Nailing

The nail is installed into the joist and header, distributing the load through two points on each joist nail for greater strength. Double-shear nailing must be full-length common nails.

Fastener Types

Fastener Types and Sizes Specified for Simpson Strong-Tie® Connectors

Many Simpson Strong-Tie connectors have been designed and tested for use with specific types and sizes of fasteners. The specified quantity, type and size of fastener must be installed in the correct holes on the connector to achieve published loads. Other factors such as fastener material and finish are also important. Incorrect fastener selection or installation can compromise connector performance and could lead to failure.

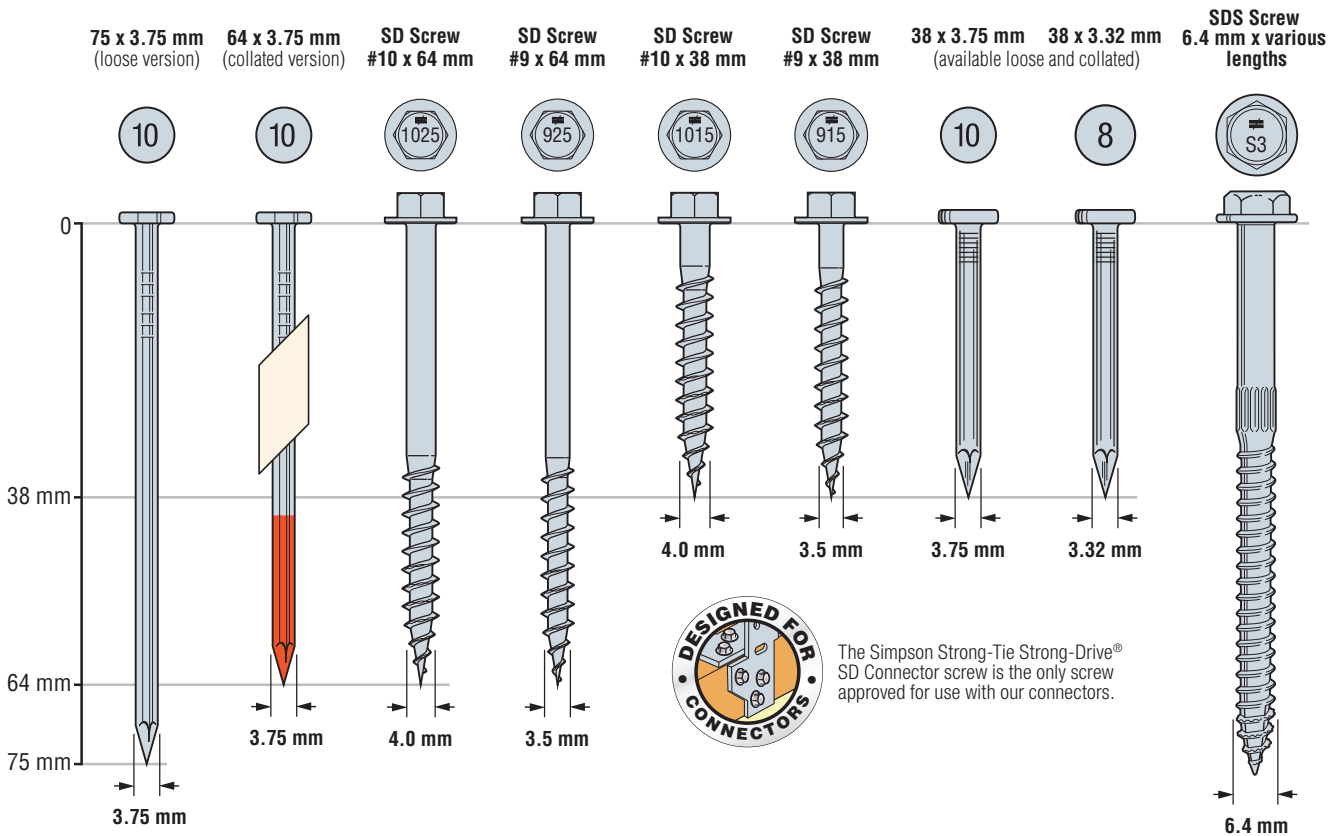

Nail diameter assumes no coating. Screw diameter refers to shank diameter.



Stainless steel connector nails with annular threads or "rings" on the shank increase withdrawal capacity. "≠" identifier on the heads for easy recognition on the job site.

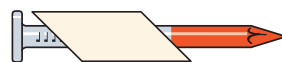

Collated HDG connector nails with orange-dipped tips provide easy nail to connector hole alignment.

How to Use This Catalogue

NZS 3604 Characteristic Capacities

For detailed information regarding how Simpson Strong-Tie tests specific products, contact Simpson Strong-Tie.

NZS 3604 Characteristic capacities (R_k) in the following tables are determined from test results witnessed and conducted by a third-party independent testing agency, using test criteria established by industry, such as Australian, New Zealand and ASTM test standards. The test results are converted into a characteristic value based on the 5th percentile of the lower probability load limit using BRANZ Evaluation Method No. 1 (1999), "Structural Joints — Strength and Stiffness Evaluation", Section 2.1.

The published characteristic values do not consider the calculated characteristic capacity of the fasteners, and are exclusively based on the ultimate load carrying performance of the connector using the fasteners prescribed in the tables.

To obtain a design resistance (ϕR_k) in accordance with NZS 3603, refer to Simpson Strong-Tie load capacity tables in Timber Construction Connector Catalogue (C-C-AU16 Revision 1).

It is not advisable to take the characteristic value, R_k , and multiply by a reduction factor for the fastener (ϕ), and load duration factor (k_d) to obtain a NZS 3603 design resistance. There are two main reasons this is not an advisable practice:

1. $R_k \times \phi \times k_d$ load capacity levels will commonly exceed desirable serviceability deflection of the joint connection, and/or connector deformation.
2. The capacity will not have an adequate safety factor to cover occurrences such as mis-installation of the connector, incorrect quantity or size of fastener used on the connector, timber defects at the joint location, and unanticipated increases in load demand.

Refer to Simpson Strong-Tie Timber Construction Connector Catalogue (C-C-AU16 Revision 1) for additional information which includes general notes, detailed connector dimensions, material thicknesses, and description of load directions (i.e. F_1 , F_2 , etc.).

Catalogue Definition

Designed to provide a secure connection when the end of a beam bears on a post, the versatile, two-piece LCE4 can accommodate 90 mm or 140 mm timber and features a universal design that eliminates right and left versions.

Material: 1 mm thick

Finish: Galvanised. See Corrosion Information.

Product Drawings
Provides a graphic presentation of the product with dimensional information (often cross referenced to the table).

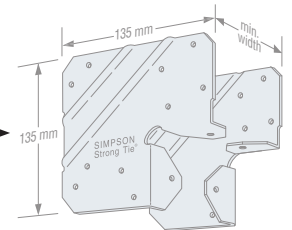

LCE4

Related Links

For more information and drawings [click here to visit webpage](#)

| Model No. | Dimensions (mm) | | Fasteners (No. – Lgth x Dia., mm) | | Characteristic Load, R_k (kN) | |
|-----------|--------------------------|-------------------------|-----------------------------------|----------------|---------------------------------|---------|
| | Lower Leg Width x Height | Overall Length x Height | Beam | Post | Section 8.6.1.8 (NZS 3604:11) | |
| | | | | | Uplift | Lateral |
| LCE4 | 75 x 60 | 137 x 137 | 14 – 64 x 3.75 | 10 – 64 x 3.75 | 24.1 | 15.3 |

1. Must be installed in pairs. Multiply Uplift and F_1 by 1.1 if using 75 mm nails in lieu of 64 mm nails.

Footnote: Footnotes in this catalogue provide addition information to aid the designer.

Related Links: Catalogue pages and Drawings are available from strongtie.co.nz

Corrosion Information

Integrated Corrosion Resistance Recommendations

Integration of treatment hazard and atmospheric corrosion hazard for the purposes of corrosion protection determination for fasteners and metal hardware in timber-frame buildings. References are AS 1604, ISO 9223, AS 1684.2 (appendix B), AS 1684.4, AS 4534 (appendix F), and NZ3604.





| Integrated Environment | Corrosion Classification | |
|------------------------|--------------------------|----------|
| | NZ Zones | ISO 9223 |
| Dry | B, C | C1 |
| Wet | B, C, D | C2, C3 |
| Elevated | B, C, D | C4 |
| Sea-Spray | D | C4, C5 |
| Uncertain | All | All |

Corrosion Resistance Classifications Table

| Integrated Environment | Material To Be Fastened | | | | | |
|------------------------|------------------------------------|-----------------------------|-----------------|-------------------------|-------------------------------|------------|
| | Untreated timber or other material | Preservative-Treated Timber | | | | |
| | | Hazard Class H1, H2 | Hazard Class H3 | Hazard Class H4, H5, H6 | Other Treatments or Uncertain | FRT Timber |
| Dry Service | Low | Low | N/A | N/A | High | Medium |
| Wet Service | Medium | N/A | Medium | High | High | High |
| Elevated Service | High | N/A | High | Severe | Severe | High |
| Uncertain | High | High | Severe | Severe | Severe | High |
| Sea-Spray | Severe | N/A | Severe | Severe | Severe | Severe |

1. These are general guidelines that may not consider all application criteria. Refer to product specific information for additional guidance.
2. Treatments typical of Hazard Classes H1 and H2 are based on inorganic boron or are preservatives in light organic solvents (LOSP).
3. Treatments typical of Hazard Class H3 is ACQ-D (retention 6.4 kg/m³), Copper Azole-B (retention 3.3 kg/m³), Copper Azole-C (retention 2.4 kg/m³)
4. Treatments for sawn products typical of Hazard Classes H4, H5, and H6 are CCA, ACZA, ACQ (retention > 6.4 kg/m³), and creosote.
5. Fire-retardant treated timber may have specific corrosion resistance requirements. See chemical manufacturer guidelines.
6. Type 316/305/304 stainless steels are recommended where preservative treated timber is used in ground contact.
7. Testing by Simpson Strong-Tie following ICC-ES AC257 has shown that mechanical galvanisation, Quik Guard coating, and Double Barrier coating will provide corrosion resistance equivalent to hot-dip galvanisation in contact with chemically treated timber in dry service and wet service exposures (Hazard Classes H1-H3) and will perform adequately subject to regular maintenance and periodic inspection.
8. Mechanical galvanisations C3 and N2000 should not be used in conditions that would be more corrosive than Hazard Class H3 (external, above ground rapid water run off).
9. If uncertain about Hazard Class, treatment chemical, or environment, use Type 316/305/304 stainless steels, silicon bronze, or copper.
10. Type 316 stainless steel, silicon bronze, and copper fasteners are the best recommendation for ocean front and chloride-containing environments. Hot-dipped galvanised fasteners, Class C protection can also be used as an alternate for some applications in environments with ocean air and/or elevated moisture content.

Choose the Right Level of Corrosion Protection

| Finish/Material | Description |
|---|---|
| <p>Corrosion Resistance Level</p> <p>LOW</p> | |
| Gray Paint | Water-based paint intended to protect the product while it is warehoused and in transit to the jobsite. |
| Powder Coating | Baked on paint finish that is more durable than our standard paint and produces a better looking finished product. |
| Z275 | Zinc galvanised coating weight of 275g of zinc per square meter, total both sides. Hot dip galvanised per ASTM A-653. |
| Electrocoating (E-Coat™) | Electrocoating utilises electrical current to deposit the coating material on the fastener. After application, the coating is cured in an oven. Electrocoating provides a minimum amount of corrosion protection and is recommended for dry, non-corrosive applications only. |
| <p>Corrosion Resistance Level</p> <p>MEDIUM</p> | |
|  | Zinc galvanised coating weight of 550g of zinc per square meter, total both sides. Hot dip galvanised per ASTM A-653. These products require hot-dip galvanised fasteners (fasteners which meet the specifications of ASTM A153). |
|  | Products are hot-dip galvanised after fabrication (2.0 mm and thicker). The coating weight increases with material thickness. The minimum average coating weight is 600g per square meter, total both sides. Hot dip galvanised per ASTM A-123. These products require hot-dip galvanised fasteners (fasteners which meet the specifications of ASTM A153). Anchor bolts are hot-dip galvanised per ASTM F2329. |
| Type 410 Stainless Steel with Protective Top Coat | Carbon martensitic grade of stainless steel which is inherently magnetic, with an added protective top coat. This material can be used in mild atmospheres and many mild chemical environments. |
|  | Simpson Strong-Tie Strong-Drive® SD Connector screw is manufactured with a mechanically-applied zinc coating in accordance with ASTM B695, Class 55 with a supplemental overcoat. These fasteners are compatible with painted and zinc-coated (Z275 and ZMAX®) connectors. |
| Double-Barrier Coating | Simpson Strong-Tie Strong-Drive SDS Heavy-Duty Connector screw is manufactured with two different finishes that together provide a level of corrosion protection that equals that provided by the previous HDG coating. |
| <p>Corrosion Resistance Level</p> <p>SEVERE</p> | |
|  | Connectors are manufactured from Type 316L stainless steel, and provide greater durability against corrosion. Stainless-steel nails are required with stainless-steel products, and are available from Simpson Strong-Tie. |

Use ZMAX® coated or stainless-steel connectors in outdoor environments and to protect against corrosion from preservative-treated wood. **Use ONLY fasteners with a hot-dip galvanised (HDG) or double-barrier coating with ZMAX® and post-HDG connectors. Use ONLY stainless-steel fasteners with stainless-steel connectors.** Visit strongtie.com/info for critical information.

General Notes and Important Information

Warning

Simpson Strong-Tie Company Inc. structural connectors, anchors, and other products are designed and tested to provide specified design capacity. To obtain optimal performance from Simpson Strong-Tie Company Inc. products and achieve maximum design capacity, the products must be properly installed and used in accordance with the installation instructions and design limits provided by Simpson Strong-Tie Company Inc. To ensure proper installation and use, Designers and installers must carefully read the following General Notes, General Instructions for the Installer and General Instructions for the Designer, as well as consult the applicable catalogue pages for specific product installation instructions and notes.

Proper product installation requires careful attention to all notes and instructions, including these basic rules:

1. Be familiar with the application and correct use of the connector.
2. Follow all installation instructions provided in the applicable catalogue, website or any other Simpson Strong-Tie publications.
3. Install all required fasteners per installation instructions provided by Simpson Strong-Tie Company Inc.: a) use proper fastener type; b) use proper fastener quantity; c) fill all fastener holes as specified; d) do not overdrive or underdrive nails, including when using gun nailers; and e) ensure screws are completely driven.
4. Only bend products that are specifically designed to be bent. For those products that required bending, do not bend more than once.
5. Cut joists to the correct length, do not "short-cut". The gap between the end of the joist and the header material should be no greater than 3.2 mm unless otherwise noted.

In addition to following the basic rules provided above as well as all notes, warnings and instructions provided in the catalogue, installers, designers, engineers and consumers should consult the Simpson Strong-Tie Company Inc. website at www.strongtie.com to obtain additional design and installation information, including:

- Instructional builder/contractor training kits containing an instructional video, an instructor guide and a student guide in both English and Spanish;
- Product specific installation videos;
- Specialty catalogues;
- Code reports – Simpson Strong-Tie® Code Report Finder software;
- Technical fliers and bulletins;
- Material safety data sheets;
- Corrosion information; and
- Answers to frequently asked questions and technical topics.

Failure to follow fully all of the notes and instructions provided by Simpson Strong-Tie Company Inc. may result in improper installation of products. Improperly installed products may not perform to the specifications set forth in this catalogue and may reduce a structure's ability to resist the movement, stress, and loading that occurs from gravity loads as well as impact events such as earthquakes and high velocity winds.

Simpson Strong-Tie Company Inc. does not guarantee the performance or safety of products that are modified, improperly installed or not used in accordance with the design and load limits set forth in this catalogue.

General Notes and Important Information

General notes

These general notes are provided to ensure proper installation of Simpson Strong-Tie Company Inc. products and must be followed fully.

- a. Simpson Strong-Tie Company Inc. reserves the right to change specifications, designs, and models without notice or liability for such changes.
- b. Steel used for each Simpson Strong-Tie® product is individually selected based on the product's steel specifications, including strength, thickness, formability, finish, and weldability. Contact Simpson Strong-Tie for steel information on specific products.
- c. Unless otherwise noted, dimensions are in millimetres and loads are in kilo Newtons.
- d. Unless otherwise noted, welds, screws, bolts and nails may not be combined to achieve highest load capacity.
- e. Do Not Overload. Do not exceed catalogue design capacities, which would jeopardise the connection.
- f. Light-timber framing in New Zealand for engineered and prescriptive design shall be in accordance with NZS 3603 and NZS 3604, respectively.
- g. Unless otherwise noted, design capacities are for Seasoned Radiata Pine, SG8, under continuously dry conditions. Design capacities for other species or conditions must be adjusted according to the code. All references to bolts or machine bolts (MBs) are for structural quality hex head bolts (*not coach screws or cuphead bolts*).
- h. Unless otherwise noted, bending steel in the field may cause fractures at the bend line. Fractured steel will not carry load and must be replaced.
- i. A fastener that splits the timber will not take the design load. Evaluate splits to determine if the connection will perform as required. Dry timber may split more easily and should be evaluated as required. If timber tends to split, consider pre-boring holes with diameters not exceeding 0.75 of the nail diameter. Use a 4.0 mm bit for SDS Heavy-Duty Connector screws and a 2.5 mm bit for SD9/SD10 Connector screws.
- j. Timber shrinks and expands as it loses and gains moisture, particularly perpendicular to its grain. Take timber shrinkage into account when designing and installing connections. Simpson Strong-Tie manufactures products to fit seasoned timber dimensions. If you need a connector with dimensions other than those listed in this catalogue, Simpson Strong-Tie may be able to vary connector dimensions; contact Simpson Strong-Tie. The effects of timber shrinkage are increased in multiple timber connections, such as floor-to-floor installations.
- k. Top flange hangers may cause unevenness. Possible remedies should be evaluated by a professional and include using a face mount hanger, and routing the beam or cutting the subfloor to accommodate the top flange thickness.
- l. Built-up timber (*multiple members*) must be fastened together to act as one unit to resist the applied load (*excluding the connector fasteners*). This must be determined by the Designer/Engineer of Record.
- m. Some model configurations may differ from those shown in this catalogue. Contact Simpson Strong-Tie for details.
- n. In some cases, combinations of these options may not be installable. Horizontal loads induced by sloped joists must be resisted by other members in the structural system. A qualified Designer must always evaluate each connection, including carried and carrying member limitations, before specifying the product. Fill all fastener holes with fastener types specified in the tables, unless otherwise noted.
- o. Truss plates shown are the responsibility of the Truss Designer.
- p. Do not weld products listed in this catalogue unless this publication specifically identifies a product as acceptable for welding, or unless specific approval for welding is provided in writing by Simpson Strong-Tie. Some steels have poor weldability and a tendency to crack when welded. Cracked steel will not carry load and must be replaced.
- q. Unless noted otherwise, all references to standard cut washers refer to Type A plain washers (W) conforming to the dimensions shown in ASME B18.22.1 for the appropriate rod size. Some products require SAE narrow washers (N) to fit in a tight space and are noted accordingly.

General Notes and Important Information

General Instructions for the Installer

These general instructions for the installer are provided to ensure proper selection and installation of Simpson Strong-Tie Company Inc. products and must be followed carefully. These general instructions are in addition to the specific installation instructions and notes provided for each particular product, all of which should be consulted prior to and during installation of Simpson Strong-Tie Company Inc. products.

- a. All specified fasteners must be installed according to the instructions in this catalogue. Incorrect fastener quantity, size, placement, type, material, or finish may cause the connection to fail. Prior to using a particular fastener, please consult the Fastener Guide in this catalogue.
 - Unless otherwise noted screws may not be used to replace nails in connectors unless approved and recommended by the Designer/Engineer of Record. Unless stated otherwise, Simpson Strong-Tie cannot and does not make any representations regarding the suitability of use or load-carrying capacities of connectors with screws replacing nails.
 - When using stainless-steel connectors, use stainless-steel fasteners. When using ZMAX®/HDG galvanised connectors, use fasteners that meet the zinc coating specifications of ASTM A153 or other fasteners allowed in this catalogue.
- b. Fill all fastener holes as specified in the installation instructions for that product. Refer to page 2 for the requirements of the various shapes of fastener hole.
- c. Do not overdrive nails. Overdriven nails reduce shear capacity.
- d. Use the materials specified in the installation instructions. Substitution of or failure to use specified materials may cause the connection to fail.
- e. Do not add fastener holes or otherwise modify Simpson Strong-Tie Company Inc. products. The performance of modified products may be substantially weakened. Simpson Strong-Tie will not warrant or guarantee the performance of such modified products.
- f. Install products in the position specified in the catalogue.
- g. Do not alter installation procedures from those set forth in this catalogue.
- h. The proper use of certain products requires that the product be bent. For those products, installers must not bend the product more than one time (*one full cycle*).
- i. Bolt holes shall be approximately 10% greater than the bolt diameter, per AS 1720 4.4.1.
- j. Install all specified fasteners before loading the connection.
- k. Some hardened fasteners may have premature failure if exposed to moisture. These fasteners are recommended to be used in dry interior applications.
- l. Use proper safety equipment.
- m. Welding galvanised steel may produce harmful fumes; follow proper welding procedures and safety precautions. Unless otherwise noted Simpson Strong-Tie® connectors cannot be welded.
- n. Pneumatic or powder-actuated fasteners may deflect and injure the operator or others. Pneumatic nail tools may be used to install connectors, provided the correct quantity and type of nails (*length and diameter*) are properly installed in the nail holes. Tools with nail hole-locating mechanisms should be used. Follow the manufacturer's instructions and use the appropriate safety equipment. Overdriving nails may reduce design capacities. Contact Simpson Strong-Tie. Powder-actuated fasteners should not be used to install connectors.
- o. Joist shall bear completely on the connector seat, and the gap between the joist end and the header shall not exceed 3.2 mm (*unless specifically noted otherwise*).
- p. For holdowns, anchor bolt nuts should be finger-tight plus ¼ to ½ turn with a hand wrench, with consideration given to possible future timber shrinkage. Care should be taken to not over-torque the nut. Impact wrenches should not be used as they may preload the holdown.
- q. Holdowns and Tension Ties may be raised off the sill as dictated by field conditions to accommodate an anchor mislocated no more than 38 mm. The holdown shall be raised off the sill at least 76 mm for every 6.4 mm that the anchor is offset from the model's centreline. Anchor bolt slope shall be no greater than 1:12 (*or 5 degrees*). Contact the Designer if the holdown anchor is offset more than 38 mm or raised more than 457 mm. Raised holdown height is measured from the top of concrete to the top of the holdown bearing plate.
- r. Fasteners are permitted to be installed through metal truss plates when approved by the Truss Designer. Installation of Simpson Strong-Tie® Strong-Drive® SDS Heavy-Duty Connector screws through metal connector plates requires the plates to be pre-drilled using a maximum of a 4 mm bit. Do not drive nails through the truss plate on the opposite side of single-ply trusses which could force the plate off the truss.
- s. For cold-formed steel applications, all screws shall be installed in accordance with the screw manufacturer's recommendations. All screws shall penetrate and protrude through the joined materials a minimum of 3 full exposed threads.
- t. Nuts shall be installed such that the end of the threaded rod or bolt is at least flush with the top of the nut.
- u. When installing hurricane ties on the inside of the wall, special considerations must be taken to prevent condensation on the inside of the completed structure in cold climates.
- v. Unless otherwise noted, connectors shown in this catalogue have been designed to be installed at the time the framing members are installed. Contact Simpson Strong-Tie for retrofit suitability of specific connectors including those manufactured in accordance with the hanger options section of this catalogue.

General Notes and Important Information

General Instructions for the Designer

These general instructions for the Designer are provided to ensure proper selection and installation of Simpson Strong-Tie Company Inc. products and must be followed carefully. These general instructions are in addition to the specific design and installation instructions and notes provided for each particular product, all of which should be consulted prior to and during the design process.

- a. The term "Designer" used throughout this catalogue is intended to mean a licensed/certified building design professional, a licensed professional engineer, or a licensed architect.
- b. All connected members and related elements shall be designed by the Designer.
- c. All installations should be designed only in accordance with the design capacities values set forth in this catalogue.
- d. NZS 3604 Characteristic capacities (R_k) in the catalogue are determined from test results witnessed and conducted by a third-party independent testing agency, using test criteria established by industry, such as Australian, New Zealand and ASTM test standards. The test results are converted into a characteristic value based on the 5th percentile of the lower probability load limit using BRANZ Evaluation Method No. 1 (1999), "Structural Joints — Strength and Stiffness Evaluation", Section 2.1.
- e. Simultaneous loads in more than one direction on a single connector must be evaluated as follows:
 Design Uplift Load / Design Uplift Capacity + Design Lateral Parallel to Plate Load / Design Lateral Parallel to Plate Capacity + Design Lateral Perpendicular to Plate Load / Design Lateral Perpendicular to Plate Capacity < 1.0.
 The three terms in the unity equation are due to the possible directions that exist to generate force on a connector. The number of terms that must be considered for simultaneous loading is at the sole discretion of the Designer and is dependent on their method of calculating wind forces and the utilisation of the connector within the structural system.
 As an alternate, certain roof-to-wall connectors (*Hurricane Ties, page 20*) can be evaluated using the following: The design load in each direction shall not exceed the published design capacities in that direction multiplied by 0.75.
- f. Simpson Strong-Tie strongly recommends the following addition to construction drawings and specifications:
 Simpson Strong-Tie® connectors are specifically required to meet the structural calculations of plan. Before substituting another brand, confirm design based on reliable published testing data or calculations. The Designer should evaluate and give written approval for substitution prior to installation.
- g. Verify that the dimensions of the supporting member are sufficient to receive the specified fasteners, and develop the top flange bearing length.
- h. Some catalogue illustrations show connections that could cause cross-grain tension or bending of the timber during loading if not sufficiently reinforced. In this case, mechanical reinforcement should be considered.
- i. For holdowns, anchor bolt nuts should be finger-tight plus $\frac{1}{8}$ to $\frac{1}{2}$ turn with a hand wrench, with consideration given to possible future timber shrinkage. Care should be taken to not over-torque the nut. Impact wrenches should not be used as they may preload the holddown.
- j. Simpson Strong-Tie will provide upon request testing data on all products that have been tested.
- k. The design capacities published in this catalogue are for use when utilising the Limit States Design methodology.
- l. For joist hangers, Simpson Strong-Tie recommends the hanger height shall be at least 60% of joist height for stability.
- m. Local and/or regional building codes may require meeting special conditions. For compliance with these requirements, it is necessary to contact the local and/or regional building authority. Except where mandated by code, Simpson Strong-Tie products do not require special inspection.
- n. Holddown and Tension Tie design capacities are based on installations with an anchor rod length of 150 mm from the concrete to top of holddown seat, yet these products may be raised to any height with consideration of the increased deflection due to additional bolt elongation. For cases where the anchor bolt is offset, Simpson Strong-Tie offers recommendations, subject to the approval of the Designer, which permit holdowns to be raised up to 460 mm maximum with a corresponding horizontal anchor bolt offset of 38 mm. See "General Instructions for the Installer" (*page 6 note q*).

Bracewall Holdowns and Tension Ties

Simpson Strong-Tie offers a wide variety of holdown devices designed and tested to address many applications and load demands.

The DTT2Z tension tie is designed for lighter-duty holdown applications on single or double studs. It installs easily with the Strong-Drive® SDS Heavy-Duty Connector screws (included).

The HTT4 tension tie installs with nails and features a nailing pattern that provides better results with less deflection.

The HDU8 Holdown is pre-deflected during the manufacturing process, virtually eliminating deflection under load due to material stretch. They install with Simpson Strong-Tie® Strong-Drive® SDS Heavy-Duty Connector screws which install easily, reduce fastener slip and provide a greater net section when compared to bolts.

For more information on holdown options, contact Simpson Strong-Tie.

Material: Carbon Steel & 316 Stainless Steel - DTT 2mm thick; HTT 3.1mm thick; HDU 3.5mm thick

Finish: DTT2Z in ZMAX®, DTT2SS in 316L SS, HTT4 and HDU8 in Z275 coating. See Corrosion Information.

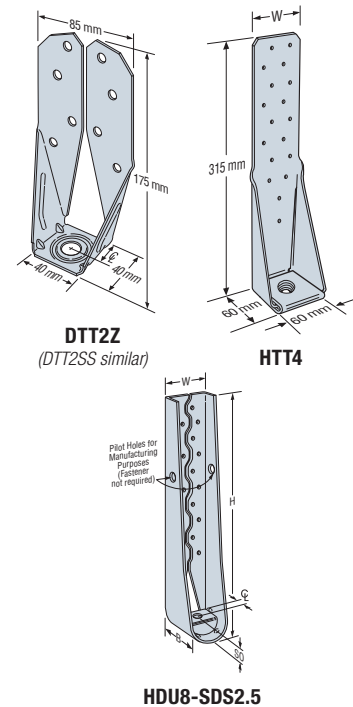

Related Links For more information and drawings [click here to visit HTT webpage](#); [click here to visit DTT webpage](#); [click here to visit HDU webpage](#)

Technical Data

| Model No. | Dimensions (mm) | | | | Fasteners | | Minimum Timber Thickness (mm) | Characteristic Load, R _k (kN) | |
|-------------|-----------------|--------|-----------------|--------------------------|----------------------|---|-------------------------------|--|------|
| | Width | Height | Foot Projection | Distance Post to Bolt CL | Anchor Hole Dia (mm) | Post Fasteners (No. – Length x Dia.) (mm) | | 15kN Uplift Bracewall Holdown | |
| DTT2Z | DTT2SS | 85 | 175 | 40 | 21 | 12 ^{1,3} | 8 – SDS6.4 x 38 | x 45 | 17.3 |
| | | | | | | | | x 90 | 18.7 |
| HTT4 | | 65 | 315 | 60 | 33 | 16 ^{2,3} | 18 – 38 x 3.75 | x 45 | 26.0 |
| | | | | | | | | x 90 | 28.1 |
| HDU8-SDS2.5 | | 75 | 420 | 90 | 35 | 20 | 20 – SDS6.4 x 64 | x 45 or x 90 | 53.0 |
| | | | | | | | | x 75 | 44.9 |
| | | | | | | | | x 90 | 52.7 |
| | | | | | | | | x 90 | 66.2 |

1. Anchor hole diameter suits 10mm Titen HD®
2. Anchor hold diameter suits 12mm Titen HD®
3. BRANZ Appraisal 983 (2023) for applications related to bottom plate fixings and holdown applications per NZS 3604 using Titen HD. Download the Branz Appraisal from <https://www.branz.co.nz/appraisal-codemark-certificates/simpson-strong-tie-bottom-plate-anchor-solutions/>
4. The Designer must specify anchor bolt type, length and embedment.

Moment Post Base

The MPB Moment Post Base is specifically designed to provide moment resistance for timber columns and posts. With its innovative sleeve design, the patent-pending MPB encapsulates the post and keeps it from rotating at its base when lateral loads are applied at the top. This provides both the specifier and the contractor with greater design options and the opportunity to reduce the need for bracing, creating more unobstructed views.

This innovative off-the-shelf solution has been engineered and tested to save specifiers and contractors the time and expense involved in designing, calculating and ordering custom-fabricated parts.

Material: Carbon Steel 2.7mm thick

Finish: ZMAX® coating. See Corrosion Information.

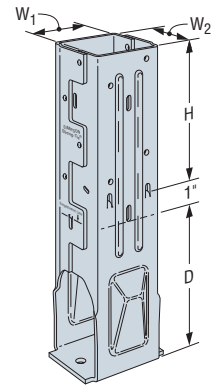

MPB44Z

Related Links For more information and drawings [click here to visit webpage](#)

Technical Data

| Model No. | Dimensions (mm) | | | Fasteners (No. – Length x Dia., mm) | Characteristic Load, R _k (kN) | | | |
|---------------|--------------------------------|-----|-----|---|--|----------------|----------------|-----------------|
| | W ₁ /W ₂ | D | H | | Uplift | F ₁ | F ₂ | Moment (kNm) |
| MPB44Z | 90 x 90 | 184 | 184 | 16 – SDS6.4 x 64 | 25.8 | 17.5 | 47.0 | 8.6 |

1. Timber species for joint design is seasoned Radiata Pine, which is Australia Joint Group JD4 per AS 1720.1 Table H2.4 and New Zealand Joint Group J5 per NZS 3603 Table 4.1.
2. Higher download can be achieved by solidly packing grout in the 1" standoff area before installation of the post. Allowable download shall be based on either the wood post design or the concrete design calculated per code.
3. Concrete shall have a minimum compressive strength of f'c = 17 Mpa
4. Foundation design (size and reinforcement) by Designer.
5. For loading simultaneously in more than one direction, the Design Capacity must be evaluated using the following equation: (Uplift / Design Uplift Capacity, or Download / Design Download Capacity) + (Moment / Design Moment Capacity) + (Lateral / Design Lateral Capacity) ≤ 1.0.

Post Bases

The ABU adjustable post base provides a high-strength connection between the post and concrete. Designed to install on hardened concrete with either a cast-in-place or post-installed anchor, the ABU is designed to provide maximum uplift performance for areas where uplift from high winds is a concern.

Finish: ABU44 and ABU66 in ZMAX® or 316L SS, ABU88 in ZMAX®. See Corrosion Information.

| Model No. | Material (mm) | |
|----------------|----------------|-----------------------|
| | Base Thickness | Knife Plate Thickness |
| ABU44Z | 1.6 | 2.7 |
| ABU66Z | 2.7 | 3.5 |
| ABU88Z5 | 2.0 | 2.7 |
| ABU44SS | 1.6 | 2.7 |
| ABU66SS | 2.7 | 3.5 |

Related Links For more information and drawings [click here to visit webpage](#)

Technical Data

| Model No. | Post Size (mm) | Dimensions (mm) | | | Fasteners | | | Characteristic Load, R _k (kN) | | |
|----------------|----------------|-----------------|------------|------------|----------------------|------------------------------------|--------------------------------|--|-------------------|-------------|
| | | Opening Width | Leg Length | Leg Height | Anchor Diameter (mm) | Opt. 1 Nails (No. – L x Dia.) (mm) | Opt. 2 Bolts (No. – Dia.) (mm) | Uplift with Nails | Uplift with Bolts | Download |
| ABU44Z | 90 x 90 | 91 | 76 | 140 | 16 | 12 – 64 x 3.75 | 2 – M12 | 27.7 | 28.8 | 81.7 |
| ABU66Z | 140 x 140 | 140 | 127 | 155 | 16 | 12 – 64 x 3.75 | 2 – M12 | 34.5 | 38.4 | 122 |
| ABU88Z | 185 x 185 | 191 | 178 | 178 | 2 – 16 | 18 – 64 x 3.75 | — | 47.1 | — | 306 |
| ABU44SS | 90 x 90 | 91 | 76 | 140 | 16 | 12 – 64 x 3.75SS | 2 – M12 | 9.9 | 30.0 | 78.4 |
| ABU66SS | 140 x 140 | 140 | 127 | 155 | 16 | 12 – 64 x 3.75SS | 2 – M12 | 26.8 | 44.4 | 169 |

1. Uplift value may be increased by 1.1 if 75 mm nails are used in lieu of 64 mm nails

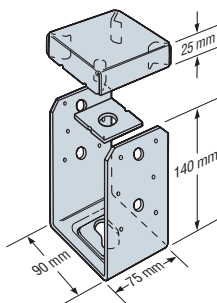

ABU44

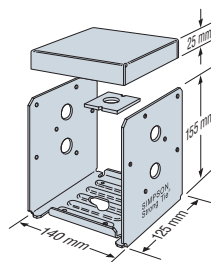

ABU66

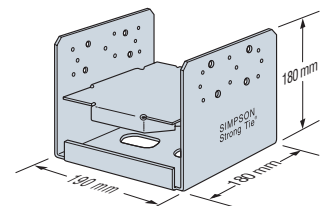

ABU88

Concealed Post Bases

The CPTZ concealed post base provides a clean, concealed look while providing a 25 mm standoff height above concrete. The 25 mm standoff, with black powder coat finish, reduces the potential for decay at the post end and satisfies code requirements for posts that are exposed to weather or water splash or are in basements.

Finish: Knife plate, washers and standoff base ZMAX® coating. The ½" (12.7 mm) diameter drift dowels are mechanically galvanised. If substituting M12 diameter bolts, a hot-dip galvanised finish is recommended. CPT4 also available in 316L SS. See Corrosion Information.

| Model No. | Material (mm) | |
|-----------|----------------|-----------------------|
| | Base Thickness | Knife Plate Thickness |
| CPT44Z | 2.7 | 3.5 |
| CPT4SS | 2.7 | 3.5 |
| CPT66Z | 2.7 | 3.5 |
| CPT88Z | 2.7 | 3.5 |

Related Links For more information and drawings [click here to visit webpage](#)

Technical Data

| Model No. | Post Size (mm) | Dimensions (mm) Width (Square) | Fasteners | | | Characteristic Load, R _k (kN) | | | |
|-----------|----------------|-----------------------------------|-----------|----------|--|--|----------|----------------|----------------|
| | | | Anchor | | Post Pins (No. – Dia. x L or Dia.) (mm) | Uplift | Download | F ₁ | F ₂ |
| | | | Qty | Dia (mm) | | | | | |
| CPT44Z | 90 x 90 | 90 | 2 | 12 | 3 – 70 x 12 | 45.5 | 124 | 11.2 | 6.8 |
| CPT44SS | | | | | | | | | |
| CPT66Z | 140 x 140 | 137 | 2 | 12 | 3 – 120 x 12 | 55.7 | 265 | 20.1 | 27.8 |
| CPT88Z | 185 x 195 | 184 | 2 | 12 | 3 – 120 x 12 | 37.0 | 230 | 39.8 | 38.4 |

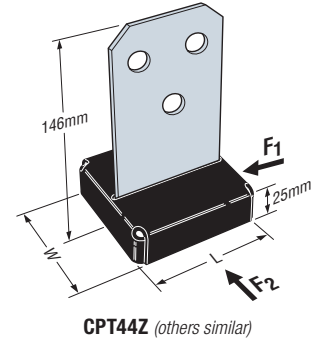

Lintel to Post Brackets

Designed to provide a secure connection when the end of a beam bears on a post, the versatile, two-piece LCE4 can accommodate 90 mm or 140 mm timber and features a universal design that eliminates right and left versions.

Material: Carbon Steel 1mm thick

Finish: Z275 coating. See Corrosion Information.

Related Links For more information and drawings [click here to visit webpage](#)

Technical Data

| Model No. | Dimensions (mm) | | Fasteners (No. – Lgth x Dia., mm) | | Characteristic Load, R _k (kN) | |
|-----------|-----------------------------|----------------------------|--------------------------------------|----------------|--|---------|
| | Lower Leg Width x Height | Overall Length x Height | Beam | Post | Uplift | Lateral |
| LCE4 | 75 x 60 | 135 x 135 | 14 – 64 x 3.75 | 10 – 64 x 3.75 | 24.1 | 15.3 |

1. Must be installed in pairs. Multiply uplift and lateral loads by 1.1 if using 75 mm nails in lieu of 64 mm nails.

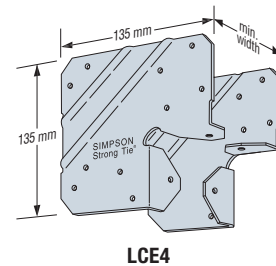

Post Caps

The BC4Z offers dual purpose post cap/base for light cap or base connections.

Material: Carbon Steel 1.3mm thick

Finish: ZMAX® coating or 316SS. See Corrosion Information.

Related Links

For more information and drawings [click here to visit webpage](#)

Technical Data

| Model No. | Dimensions (mm) | | | Fasteners (No. – Lgth x Dia., mm) | | Characteristic Load, R _k (kN) | |
|-----------|---|---|--|--------------------------------------|------------------|--|---------|
| | Opening Width (W ₁ , W ₂) | Leg Width (L ₁ , L ₂) | Leg Height (H ₁ , H ₂) | Beam Flange | Post Flange | Uplift | Lateral |
| BC4Z | 90 | 73 | 76 | 6 – 64 x 3.75 | 6 – 64 x 3.75 | 10.9 | 10.4 |
| BC4SS | 90 | 73 | 76 | 6 – 64 x 3.75SS | 6 – 64 x 3.75SS | 10.9 | 10.4 |
| BC6Z | 140 | 111 | 86 | 12 – 64 x 3.75 | 12 – 64 x 3.75 | 17.7 | 24.4 |
| BC6SS | 140 | 111 | 86 | 12 – 64 x 3.75SS | 12 – 64 x 3.75SS | 17.7 | 24.4 |

1. Uplift and lateral load values may be increased by 1.1 if 75 mm nails are used in lieu of 64 mm nails

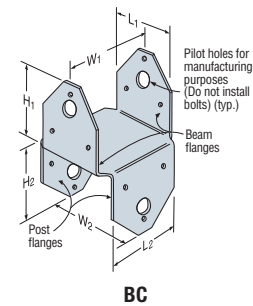

Concealed Joist Hangers

The CJT concealed joist tie offers tested performance in a joist connector with a clean, concealed look. Designed for versatility as well as hidden beauty, the CJT allows the joist to be angled up to 45° up or down with no reduction in load.

Material: Carbon Steel 2.7mm thick

Finish: ZMAX® coating. See Corrosion Information.

Related Links For more information and drawings [click here to visit webpage](#)

Technical Data

| Model No. | Min. Joist Size (mm) | Dimensions (mm) | | Fasteners (No. – Lgth x Dia., mm) | | Characteristic Load, R _k (kN) | |
|-----------|----------------------|----------------------------------|--------------------------------------|-----------------------------------|-------------|--|----------|
| | | Bracket Height (H ₁) | Knife Plate Height (H ₂) | Post | Joist Pins | Uplift | Download |
| CJT3ZS | 90 x 140 | 140 | 112 | 6 – SDS6.4 x 76 | 3 – 12 x 70 | 16.8 | 23.2 |
| | 90 x 184 | 140 | 112 | 6 – SDS6.4 x 76 | 3 – 12 x 70 | 19.6 | 29.0 |
| CJT4ZS | 90 x 235 | 178 | 151 | 8 – SDS6.4 x 76 | 4 – 12 x 70 | 32.7 | 38.4 |
| CJT5ZS | 90 x 286 | 216 | 188 | 10 – SDS6.4 x 76 | 5 – 12 x 70 | 39.0 | 45.6 |
| CJT6ZS | 90 x 286 | 255 | 227 | 12 – SDS6.4 x 76 | 6 – 12 x 70 | 59.2 | 49.3 |

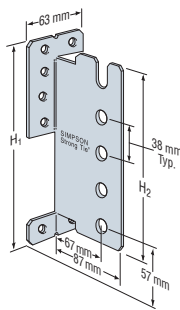

CJT5
(Others similar)

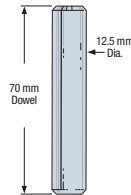

Chamfered steel dowel

Internal Flange Joist Hangers

The IUC is a face-mounted concealed flange hanger for both I-joists and solid timber sections. Ideal for end of ledger/header or post conditions, the IUC also provides cleaner lines for exposed conditions such as overhead decks.

Material: Carbon Steel; IUC 1.2mm thick, HUC 2mm thick. Stainless Steel SAIX 1.5mm thick

Finish: Z275 Galvanised: IUC
ZMAX® Galvanised: HUC48Z
316 Stainless Steel: SAIX440/90/1.5
See Corrosion Information.

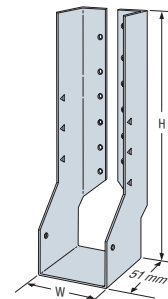

IUC
(Others similar)

Related Links For more information and drawings [click here to visit webpage](#)

Technical Data

| Model No. | Joist size (mm) | | Dimensions (mm) | | | Fasteners (No. – Lgth x Dia., mm) | | Characteristic Load, R _k (kN) | |
|----------------|-----------------|---------|-----------------|-------|------------|-----------------------------------|---------------|--|----------|
| | Width | Height | Height | Width | Seat Depth | Face | Joist | Uplift | Download |
| IUC142/47 | 45 | 140–230 | 142 | 47 | 51 | 6 – 38 x 3.75 | 2 – 38 x 3.75 | 3.1 | 10.2 |
| IUC192/47 | | 195–320 | 192 | | | 10 – 38 x 3.75 | 2 – 38 x 3.75 | 3.1 | 11.6 |
| HUC48Z | 90 | 190–300 | 173 | 90 | 64 | 14 – 75x3.75 | 6 – 75x3.75 | 10.4 | 27.8 |
| SAIX440/90/1.5 | | 190–250 | 175 | 90 | 87 | 22 – 38x3.75 | 12 – 38x3.75 | 12.8 | 16.7 |

Heavy Duty Joist Hangers

The SAE face mount joist hanger is designed for applications where extra load resistance is needed.

Material: Carbon Steel 2.0mm thick; Stainless steel versions 1.5 mm thick.

Finish: Z275 coating. Some models available in 316L SS.
See Corrosion Information.

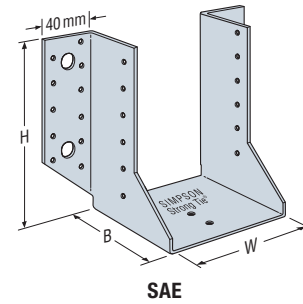

SAE

Related Links

For more information and drawings [click here to visit webpage](#)

Technical Data

| Model No. | Joist size (mm) | | Dimensions (mm) | | | Fasteners (No. – Lgth x Dia., mm) | | Characteristic Load, R _k (kN) | |
|----------------|-----------------|---------|-----------------|--------|------------|--------------------------------------|----------------|--|----------|
| | Width | Height | Width | Height | Seat Depth | Face | Joist | Uplift | Download |
| SAE200/46/2 | 45 | 90–120 | 45 | 77 | 84 | 8 – 38 x 3.75 | 4 – 38 x 3.75 | 7.3 | 16.6 |
| SAE250/46/2 | | 115–150 | 45 | 102 | 84 | 12 – 38 x 3.75 | 7 – 38 x 3.75 | 12.8 | 14.0 |
| SAE340/46/2 | | 160–220 | 45 | 147 | 84 | 22 – 38 x 3.75 | 12 – 38 x 3.75 | 22.0 | 28.6 |
| SAE500/46/2 | | 240–340 | 46 | 227 | 84 | 34 – 38 x 3.75 | 18 – 38 x 3.75 | 32.9 | 40.5 |
| SAE500/90/2 | 90 | 225–340 | 90 | 205 | 75 | 34 – 38 x 3.75 | 18 – 38 x 3.75 | 32.9 | 40.5 |
| SAE620/91/2 | | 285–460 | 90 | 265 | 84 | 40 – 38 x 3.75 | 22 – 38 x 3.75 | 40.2 | 52.6 |
| SAEX440/90/1.5 | 90 | 190–250 | 90 | 175 | 87 | 22 – 38x3.75 | 12 – 38x3.75 | 12.8 | 16.7 |

Double Shear Joist Hangers

The LUS joist hangers are value engineering at its finest. All hangers in the LUS series have Double-Shear Nailing. This innovation distributes the load through two points on each joist nail for greater strength. It also allows the use of fewer nails, faster installation and the use of standard nails for all connections.

To help with installation speed every galvanised LUS Joist Hanger incorporates the Simpson Strong-Tie Speed Prong feature which is designed to temporarily position and secure the connector for easier and faster installation.

Material: Carbon Steel or Stainless Steel 1.2mm thick: LUS46
Carbon Steel 2mm thick: HUS48Z

Finish: ZMAX® coating or 316L SS. See Corrosion Information.

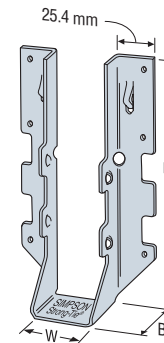

LUS

Related Links

For more information and drawings [click here to visit webpage](#)

Technical Data

| Model No. Stainless Steel (add "SS") Galvanised (add "Z") | Joist size (mm) | | Dimensions (mm) | | | Fasteners (No. – Lgth x Dia., mm) | | Characteristic Load, R _k (kN) | |
|---|-----------------|---------|-----------------|--------|------------|--------------------------------------|---------------|--|----------|
| | Width | Height | Width | Height | Seat Depth | Face | Joist | Uplift | Download |
| LUS46/77 | 45 | 90–130 | 46 | 77 | 45 | 4 – 38 x 3.75 | 2 – 64 x 3.75 | 5.6 | 12.6 |
| LUS46/118 | | 120–190 | 46 | 118 | 45 | 4 – 38 x 3.75 | 4 – 64 x 3.75 | 10.2 | 18.1 |
| LUS46/166 | | 175–280 | 46 | 166 | 45 | 6 – 38 x 3.75 | 4 – 64 x 3.75 | 10.2 | 18.7 |
| HUS48Z | 90 | 190–300 | 90 | 176 | 51 | 6 – 75x3.75 | 6 – 75x3.75 | 9.7 | 24.9 |

1. Uplift and downloads may be increased by 1.1 if 75 mm nails are used in lieu of 64 mm nails.

Split Joist Hangers

The SDE is a two-piece, width-adjustable joist hanger that can accommodate joist widths from 60 mm and 120 mm. Each SDE is comprised of one left and one right piece.

Material: Carbon Steel 2mm thick.

Finish: Z275 coating. See Corrosion Information.

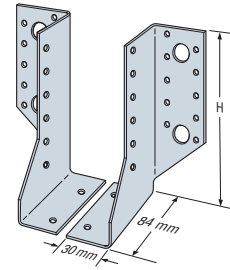

SDE

Related Links

For more information and drawings [click here to visit webpage](#)

Technical Data

| Model No. | Joist size (mm) | | Dimensions (mm) | | | Fasteners (No. – Lgth x Dia., mm) | | Characteristic Load, R _k (kN) | |
|-----------|-----------------|---------|-----------------|--------|------------|-----------------------------------|----------------|--|----------|
| | Width | Height | Width | Height | Seat Depth | Face | Joist | Uplift | Download |
| SDE340/30 | 60–120 | 140–207 | 30 | 140 | 84 | 22 – 38 x 3.75 | 16 – 38 x 3.75 | 20.8 | 41.4 |
| SDE380/30 | | 160–237 | 30 | 160 | 84 | 22 – 38 x 3.75 | 16 – 38 x 3.75 | 20.8 | 41.4 |
| SDE440/30 | | 190–282 | 30 | 190 | 84 | 28 – 38 x 3.75 | 20 – 38 x 3.75 | 29.1 | 53.5 |

I-Joist Hangers

The IUSE is a hybrid hanger that incorporates the advantages of a face mount and top mount hanger. Installation is fast with the Strong-Grip™ seat, easy-to-reach face nails and self-jigging locator tabs.

Material: Carbon Steel 1.2mm thick.

Finish: Z275 coating. See Corrosion Information.

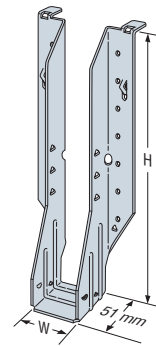

IUSE

Related Links

For more information and drawings [click here to visit webpage](#)

Technical Data

| Model No. | Joist size (mm) | | Dimensions (mm) | | | Fasteners (No. – Lgth x Dia., mm) | | Characteristic Load, R _k (kN) | |
|------------|-----------------|--------|-----------------|--------|------------|-----------------------------------|---------------|--|----------|
| | Width | Height | Width | Height | Seat Depth | Face | Joist | Uplift | Download |
| IUSE199/48 | 45 | 200 | 48 | 199 | 51 | 10 – 64 x 3.75 | 2 – 38 x 3.75 | 4.5 | 15.2 |
| IUSE239/54 | 51 | 240 | 54 | 239 | 51 | 14 – 64 x 3.75 | | 4.5 | 15.1 |
| IUSE299/54 | | 300 | | 299 | | 16 – 64 x 3.75 | | 4.5 | 15.1 |
| IUSE239/66 | 63 | 240 | 66 | 239 | 51 | 14 – 64 x 3.75 | | 4.5 | 10.4 |
| IUSE244/66 | | 245 | | 244 | | 14 – 64 x 3.75 | | 4.5 | 14.3 |
| IUSE299/66 | | 300 | | 299 | | 16 – 64 x 3.75 | | 4.5 | 15.1 |
| IUSE239/73 | 70 | 240 | 73 | 239 | 51 | 14 – 64 x 3.75 | | 4.5 | 14.3 |
| IUSE299/73 | | 300 | | 299 | | 16 – 64 x 3.75 | | 4.5 | 15.1 |
| IUSE199/92 | 90 | 200 | 92 | 199 | 51 | 10 – 64 x 3.75 | | 4.5 | 19.5 |
| IUSE239/92 | | 240 | | 239 | | 14 – 64 x 3.75 | | 4.5 | 26.8 |
| IUSE299/92 | | 300 | | 299 | | 16 – 64 x 3.75 | | 4.5 | 15.1 |
| IUSE359/92 | | 360 | | 359 | | 20 – 64 x 3.75 | | 4.5 | 14.3 |
| IUSE399/92 | | 400 | | 399 | | 22 – 64 x 3.75 | | 4.5 | 14.3 |

1. Downloads may be increased by 1.1 if 75 mm nails are used in lieu of 64 mm nails.

Slopeable/Skewable Joist Hangers

The innovative design of the LSSR Slopeable & Skewable Rafter Hanger allows it to adjust for skew up to 45° and features an innovative hinged swivel seat to adjust for up to a 45° slope on site, eliminating the need for pre-skewed/sloped or custom-order hangers. One of its key features is that it can be installed after all of the rafters have been tacked into place. Now one hanger can handle a wide range of framing applications.

Material: Carbon Steel. LSSR1.81Z – 1.3mm, LSSR410Z – 1.6mm.

Finish: ZMAX® coating. See Corrosion Information.

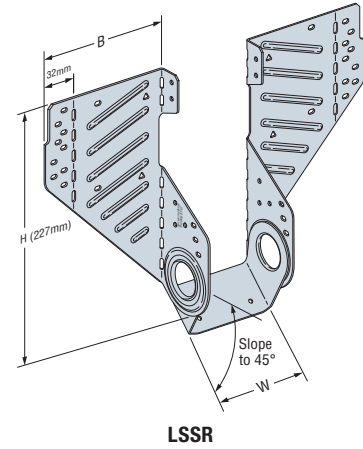

Related Links

For more information and drawings [click here to visit webpage](#)

Technical Data

| Model No. | Joist size (mm) | | Fasteners (No. – Lgth x Dia., mm) | | Characteristic Load, R _k (kN) | |
|---|-----------------|----------------|-----------------------------------|-------------|--|--|
| | Width | Face | Joist | Uplift | Download | |
| Sloped, Skewed, or Sloped & Skewed Hangers | | | | | | |
| LSSR1.81Z | 46 | 13 – 64 x 3.75 | 9 – 38 x 3.75 | 3.34 | 14 | |
| LSSR410Z | 90 | 20 – 64 x 3.75 | 13 – 64 x 3.75 | 7.6 | 22.9 | |

1. On the acute side of the skewed LSSR hangers, fill obround holes only.
2. Joist nails may be driven up to a 45-degree angle into the joist at a skewed installation to achieve the tabulated loads.

Ridge Rafter Connector

The RR ridge rafter connector provides a solid connection between rafter and ridge beam.

Material: Carbon Steel 1.2mm thick.

Finish: Z275 coating. See Corrosion Information.

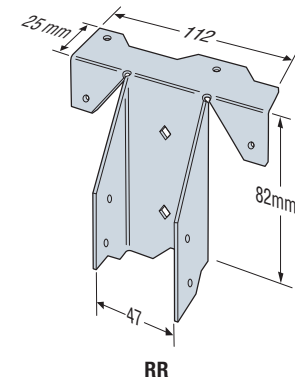

Related Links

For more information and drawings [click here to visit webpage](#)

Technical Data

| Model No. | Min Rafter Size (mm) | | Fasteners (No. – Lgth x Dia., mm) | | Characteristic Load, R _k (kN) | |
|-------------|----------------------|--------|-----------------------------------|---------------|--|------------|
| | Width (A) | Height | Ridge Beam | Rafter | Uplift | Download |
| RR47 | 45 | 112 | 4 – 38 x 3.75 | 4 – 38 x 3.75 | 1.5 | 5.6 |

Sloped Rafter to Top Plate Connectors

The VPA variable pitch connector is a versatile, field-adjustable solution for connecting rafters to the wall top plate. It adjusts in the field to accommodate slopes between 14 degrees and 45 degrees, making it a complement to the versatile LSSU joist hanger.

Material: Carbon Steel 1.3mm thick.

Finish: Z275 coating. See Corrosion Information.

Related Links

For more information and drawings [click here to visit webpage](#)

Technical Data

| Model No. | Joist Width (mm) | Fasteners (No. – Lgth x Dia., mm) | | Characteristic Load, R_k (kN) | | | |
|-----------|------------------|-----------------------------------|----------------|---------------------------------|----------|-------|-------|
| | | Carrying Member | Carried Member | Uplift | Download | F_1 | F_2 |
| VPA25 | 45 | 8 – 64 x 3.75 | 2 – 38 x 3.75 | 3.4 | 14.5 | 4.5 | 4.9 |

1. Uplift/ F_1 and F_2 may be increased by 1.1 if 75 mm nails are used in lieu of 64 mm nails.

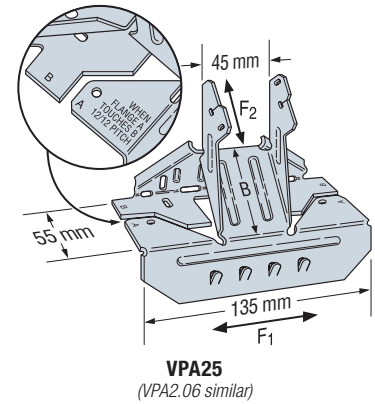

Jack Truss Connectors

TJC is a versatile connector for jack trusses. Adjustable from 0 to 85 degree (shipped with 67.5 degree bend). Nail hole locations allow for easy installation.

Material: Carbon Steel 1.6mm thick.

Finish: Z275 coating. See Corrosion Information.

Related Links

For more information and drawings [click here to visit webpage](#)

Technical Data

| Model No. | Fasteners (No. – Lgth x Dia., mm) | | Characteristic Load, R_k (kN) | |
|---------------------------------------|-----------------------------------|----------------|---------------------------------|----------|
| | Carrying Member | Carried Member | Angle | Download |
| TJC37 (Round holes) | 4 – 38 x 3.32 | 4 – 38 x 3.32 | 0° | 4.5 |
| | | | 1° to 60° | 3.6 |
| | | | 61° to 67.5° | 4.0 |
| | | | 68° to 85° | 3.3 |
| TJC37 (Round and triangular holes) | 6 – 38 x 3.32 | 6 – 38 x 3.32 | 0° | 6.4 |
| | | | 1° to 60° | 6.3 |
| | | | 61° to 67.5° | 4.9 |
| | | | 68° to 85° | 5.8 |

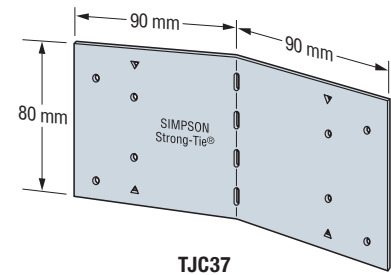

Scissor Truss to Top Plate Connectors

The TC truss connector is designed to attach trusses to the top of walls. They are typically used at each end of the truss as determined by the Designer.

Material: Carbon Steel 1.6mm thick.

Finish: Z275 coating. See Corrosion Information.

Related Links

For more information and drawings [click here to visit webpage](#)

Technical Data

| Model No. | Fasteners (No. – Lgth x Dia., mm) | | Characteristic Load, R _k (kN) |
|-------------|--------------------------------------|---------------|---|
| | Truss | Plate | Uplift |
| TC24 | 4 – 64 x 3.75 | 4 – 64 x 3.75 | 3.9 |

1. Uplift may be increased by 1.1 if 75 mm nails are used in lieu of 64 mm nails.

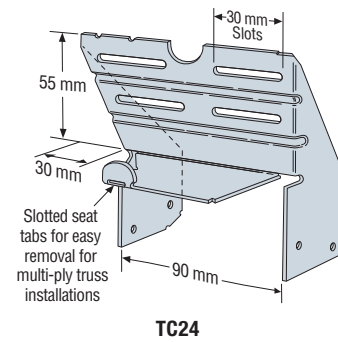

TC24

Straps

CS are continuous utility straps which can be cut to length on the jobsite. Packaged in lightweight (about 18kg) cartons.

Material: See table below.

Finish: Z275 coating. See Corrosion Information.

Related Links

For more information and drawings [click here to visit webpage](#)

Technical Data

| Model No. | Total Length (m) | Width (mm) | Thickness (mm) | Fasteners (No. – Lgth x Dia., mm) | End Length (mm) | Characteristic Load, Q _k (kN) |
|-----------------------------|------------------|------------|----------------|---|--------------------|---|
| | | | | | | Nail Capacity |
| CS18 CS18S | 61 | 32.0 | 1.3 | 16 – 64 x 3.75 | 229 | 8.9 |
| | 30 | | | 18 – 38 x 3.32 | | 8.1 |
| CS20 | 76 | 32.0 | 1.0 | 12 – 64 x 3.75 | 153 | 6.6 |
| | | | | 14 – 38 x 3.32 | | 6.2 |

1. Tension may be increased by 1.1 if 75mm nails are used in lieu of 64mm nails.

2. Nail capacity is based on the number of nails shown. Values may be increased or decreased based on the ratio of nails used.

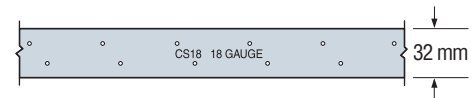

CS18 (CS20 similar)

Framing Angles

Our line of angles provides a way to make a wide range of 90° connections.

Material: Carbon Steel 1.3mm thick.

Finish: Z275 coating. See Corrosion Information.

Related Links

For more information and drawings [click here to visit webpage](#)

Technical Data

| Model No. | Dimensions (mm) | | Fasteners (No. – Lgth x Dia., mm) | | Characteristic Load, R _k (kN) | |
|-----------|-----------------|------------|--------------------------------------|---------------|--|----------------|
| | Width | Leg Height | Base | Post | F ₁ | F ₂ |
| A21 | 35 | 50 | 2 – 38 x 3.75 | 2 – 38 x 3.75 | 2.8 | 2.1 |
| A23 | 70 | 50 | 4 – 38 x 3.75 | 4 – 38 x 3.75 | 5.6 | 4.2 |

1. Double angles to achieve 2x load

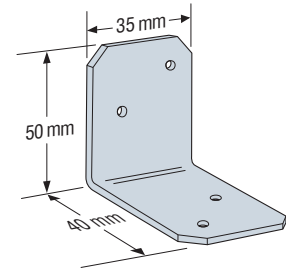

A21

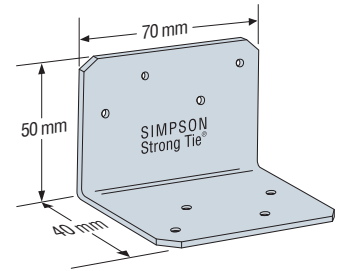

A23

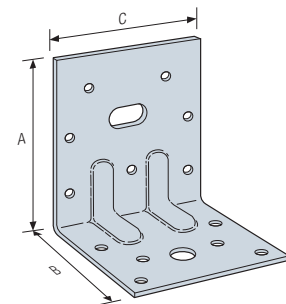

E5

Reinforced Framing Angles

E5 Reinforced Angle Brackets are suitable for structural applications in framing and timber-frame houses for general connecting of timber at 90° angles.

Typical application include fixing trusses, purlins and posts. Suitable support materials include solid timber, composite timber, laminated timber and trusses.

Material: Carbon Steel & 316 Stainless Steel 1.5mm thick.

Finish: Zmax coating or 316SS. See Corrosion Information.

Related Links

For more information and drawings [click here to visit webpage](#)

Technical Data

| Model No. | Dimensions (mm) | | | Fasteners (No. – Lgth x Dia., mm) | | Characteristic Load, R _k (kN) |
|-----------|-----------------|----|----|--------------------------------------|------------------|--|
| | A | B | C | Top Plate | Truss/Rafter | |
| E5 | 75 | 48 | 65 | 6 – SD#10 x 64mm | 7 – SD#10 x 38mm | 8.3 |
| | | | | 6 – SD#10 x 64mm | 7 – 38 x 3.75mm | 7.1 |
| E5SS | | | | 6 – CSA5,0X35S | 7 – CSA5,0X35S | 4.8 |
| | | | | 6 – CSA5,0X35S | 7 – 38 x 3.75SS | 6.9 |

Our line of angles provides a way to make a wide range of 90° connections.

Material: Carbon Steel 1.3mm thick.

Finish: Z275 coating. See Corrosion Information.

Related Links

For more information and drawings [click here to visit webpage](#)

Technical Data

| Model No. | Dimensions (mm) | | Fasteners (No. – Lgth x Dia., mm) | Characteristic Load, R _k (kN) | |
|-----------|-----------------|------------|--------------------------------------|--|----------------|
| | Width | Leg Height | | F ₁ | F ₂ |
| GA1 | 70 | 25 | 4 – 38 x 3.75 | 3.0 | 2.5 |

1. Double angles to achieve 2x load

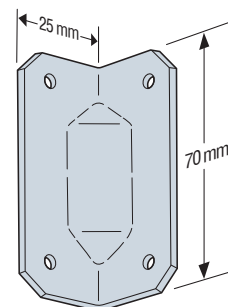

GA1

Multi-Use Framing Angles

Our line of angles provides a way to make a wide range of 90° connections.

Material: Carbon Steel 1.3mm thick.

Finish: Z275 coating or 316SS. See Corrosion Information.

Related Links

For more information and drawings [click here to visit webpage](#)

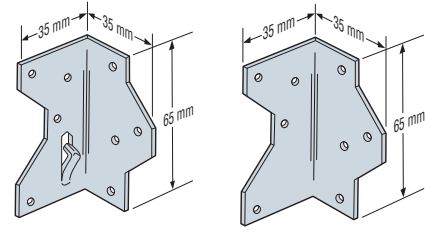

A34

A34SS

Technical Data

| Model No. | Dimensions (mm) | | Type of Connection | Fasteners (No. – Lgth x Dia., mm) | Direction of Load | Characteristic Load, R _k (kN) |
|--------------|------------------|----------------|--------------------|-----------------------------------|-----------------------------|--|
| | Width | Leg Height | | | | |
| A34 | 65 | 35 | 1 | 8 – 38 x 3.32 | F ₁ | 5.8 |
| A35 | 115 | 35 | 2 | 9 – 38 x 3.32 | F ₂ ² | 5.3 |
| | | | | | A ₁ , E | 4.0 |
| | | | 3 | 12 – 38 x 3.32 | C ₁ | 2.5 |
| | | | | | A ₂ | 4.3 |
| 4 | 12 – 38 x 3.32 | C ₂ | 3.7 | | | |
| | | D | 2.6 | | | |
| A34SS | 65 | 35 | 1 | 8 – 38 x 3.32SS | F ₁ | 5.8 |
| A35SS | 115 | 35 | 2 | 9 – 38 x 3.32SS | F ₂ ² | 5.3 |
| | | | | | A ₁ , E | 4.0 |
| | | | 3 | 12 – 38 x 3.32SS | C ₁ | 2.5 |
| | | | | | A ₂ | 4.3 |
| 4 | 12 – 38 x 3.32SS | C ₂ | 3.7 | | | |
| | | D | 2.6 | | | |
| | | | | | F ₁ | 6.1 |
| | | | | | F ₂ ² | 7.3 |

1. All loads shown are for a single angle.
2. Connectors are required on both sides to achieve F₂ load in both directions

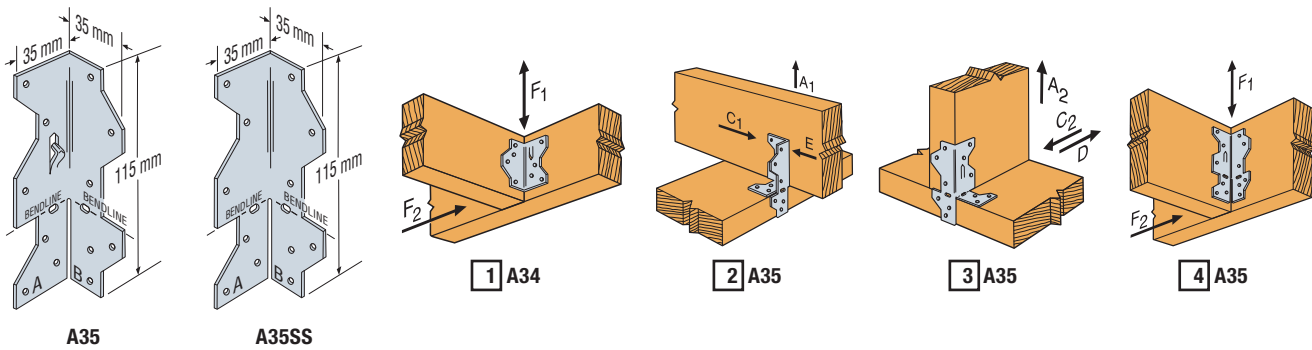

Hurricane Ties

Hurricane ties provide a positive connection between the truss/rafter and the wall of the structure to resist wind and seismic forces.

Material: See table below.

Finish: Z275 coating or 316SS. See Corrosion Information.

Related Links

For more information and drawings [click here to visit webpage](#)

Technical Data

| Model No. | Thickness (mm) | Fasteners (No. – Lgth x Dia., mm) | | | Characteristic Load, R _k (kN) | | |
|-----------|----------------|--------------------------------------|-----------------|---------------|--|----------------|----------------|
| | | To Rafters Truss | To Plates | To Studs | Uplift | Lateral | |
| | | | | | | F ₁ | F ₂ |
| H1.81Z | 1.3 | 6 – 38 x 3.75 | 4 – 38 x 3.75 | — | 4.3 | 4.4 | 2.2 |
| H2.5A | 1.3 | 5 – 38 x 3.32 | 5 – 38 x 3.32 | — | 5.3 | 3.3 | 2.9 |
| H2.5ASS | 1.3 | 5 – 38 x 3.32SS | 5 – 38 x 3.32SS | — | 5.3 | 2.3 | 2.0 |
| H3 | 1.3 | 4 – 38 x 3.32 | 4 – 38 x 3.32 | — | 5.7 | 1.6 | 5.7 |
| H3SS | 1.3 | 4 – 38 x 3.32SS | 4 – 38 x 3.32SS | — | 5.7 | 1.6 | 5.7 |
| H6 | 1.6 | — | 8 – 38 x 3.32 | 8 – 38 x 3.32 | 14.0 | — | — |

1. Double ties to achieve 2x load

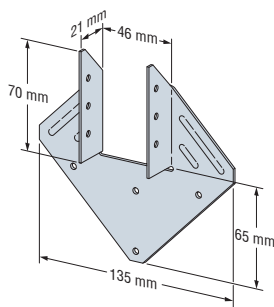

H1.81Z

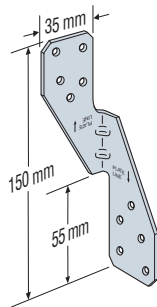

H2.5A
(H2.5SS similar)

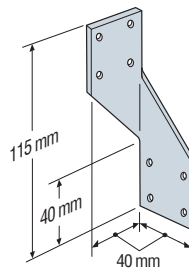

H3
(H3SS similar)

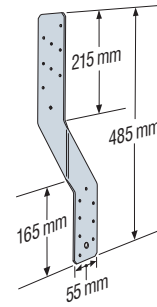

H6

Deck Tension Ties/Ballustrade Restraint

The DTT1Z and DTT2Z tension ties are safe, cost-effective connectors designed to help build stronger, safer decks that meet or exceed code requirements. The DTT1 is an easy-to-install method to provide a lateral-load connection between the deck and the adjacent structure. The DTT2 can be used for the lateral-load connection as well, but is ideal for the installation of guardrail posts that are able to resist the lateral forces that occur at the top of railing assemblies.

Material: Carbon Steel 2mm thick.

Finish: DTT1Z/DTT2Z – ZMAX® coating;
DTT2SS – 316SS. See Corrosion Information.

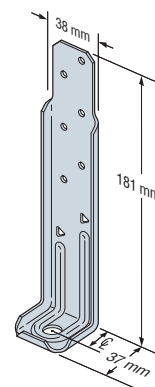

DTT1Z

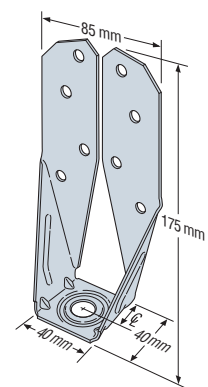

DTT2Z
(DTT2SS similar)

Related Links

For more information and drawings [click here to visit webpage](#)

Technical Data

| Model No. | Dimensions (mm) | | | Fasteners | | | Minimum Wood Member Thickness (Breadth or Depth x Breadth, mm) | Characteristic Load, R _k (kN) |
|-------------------|-----------------|--------|------------|----------------------------|--|---|---|--|
| | Width | Height | Seat Depth | Distance Post to Bolt (CL) | Anchor Hole Dia (mm) | Post Fasteners (No. – Length x Dia.) (mm) | | |
| DTT1Z DTT1Z-KT | 38 | 181 | 37 | 19 | 10mm bolt or SDWH 7mm x 200mm screw | 6 – 38 x 3.75 6 – SD#9 x 38 | 90 x 38 | 10.0 10.0 |
| DTT2Z DTT2SS | 85 | 175 | 40 | 21 | 12 | 8 – SDS6.4 x 38 8 – SDS6.4 x 38SS | 90 x 38 90 x 75 | 17.3 18.7 |

Staircase Tread Angles

TA staircase angles make it easier to build structurally sound stairs. Installing stair treads with TA angles instead of notching the stringers saves time and results in a full cross-section stringer.

Material: Carbon Steel 2.7mm thick.

Finish: ZMAX® or 316SS. See Corrosion Information.

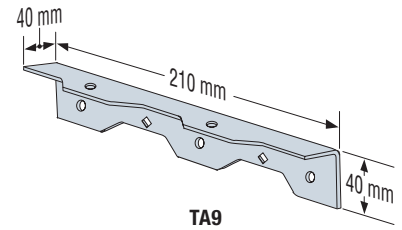

Related Links

For more information and drawings [click here to visit webpage](#)

Technical Data

| Model No. | Fasteners (No. – Lgth x Dia., mm) | | Characteristic Load, R _k (kN) |
|-----------|--------------------------------------|-------------------|--|
| | Stringer | Tread | Download |
| TA9Z-R | 3 – SDS6.4 x 38 | 2 – SDS6.4 x 38 | 22.8 |
| TA9SS | 3 – SDS6.4 x 38SS | 2 – SDS6.4 x 38SS | 22.8 |

Staircase Stringer Connectors

The LSC adjustable stair-stringer connector offers a versatile, concealed connection between the stair stringer and the carrying header or rim joist while replacing costly framing. Field slopeable to all common stair-stringer pitches, the LSC connector is suitable for either solid or notched stringers.

Material: Carbon Steel 1.3mm thick.

Finish: ZMAX® or 316SS. See Corrosion Information.

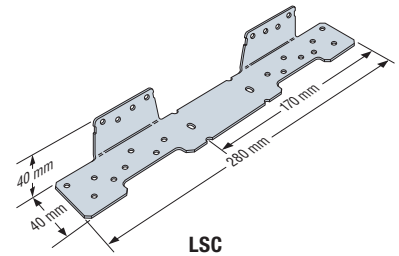

Related Links

For more information and drawings [click here to visit webpage](#)

Technical Data

| Model No. | Rim Joist Installation | Fasteners (No. – Lgth x Dia., mm) | | | Characteristic Load, R _k (kN) |
|-----------|------------------------|--------------------------------------|--------------------|----------------------|--|
| | | Rim Joist ⁶ | Stringer Wide Face | Stringer Narrow Face | Download |
| LSCZ | Supported ⁸ | 8 – 38 x 3.75 | 8 – 38 x 3.75 | 1 – 38 x 3.75 | 6.0 |
| | | 8 – SD#9 x 38 | 8 – SD#9 x 38 | – | 5.3 |
| | Standard | 8 – 38 x 3.75 | 8 – 38 x 3.75 | 1 – 38 x 3.75 | 8.5 |
| | | 8 – SD#9 x 38 | 8 – SD#9 x 38 | 1 – SD#9 x 38 | 8.5 |
| | Cantilever | 8 – 38 x 3.75 | 8 – 38 x 3.75 | 1 – 38 x 3.75 | 2.9 |
| | | 8 – SD#9 x 38 | 8 – SD#9 x 38 | – | 6.5 |

1. LSCSS must use SS nails or screws

Structural Fasteners for Connecting Timber-To-Timber

Strong-Drive® SDWC TRUSS Screw

The Strong-Drive® SDWC TRUSS screw provides a truss and rafter-to-top plate connection as well as a method to fasten studs to top or bottom plates. The fully-threaded shank engages the entire length of the fastener providing a secure connection.

Material: Carbon steel.

Finish: SDWC15450—E-Coat™; SDWC15600—Clear Zinc Coating (with Orange Topcoat). See Corrosion Information.

Related Links For more information and drawings [click here to visit webpage](#)

Technical Data

| Model No. | Fastener Length (mm) | Thread Length (mm) | Side Member (SG8) | Main Member (SG8) | Characteristic Lateral Load, R_k (kN) | | Characteristic Load, R_k (kN) |
|-----------|----------------------|--------------------|------------------------|----------------------------|---|-------|---------------------------------|
| | | | | | F_1 | F_2 | Uplift |
| SDWC15450 | 114 | 108 | Single Plate (45mm) | Single Stud (45mm) | — | 3.5 | 6.1 |
| SDWC15600 | 152 | 136 | Double Plate (80–90mm) | Single Joist/Rafter (45mm) | 2.8 | 4.3 | 11.8 |
| | | | Single Plate (45mm) | Single Stud (45mm) | — | 2.5 | 6.1 |
| | | | Double Plate (80–90mm) | Single Stud (45mm) | — | 3.5 | 8.9 |

1. Main Member is the part where the fastener tip is embedded. Side Member is the part adjacent to the fastener head.
2. F_1 is loading parallel to the wall (in the wall plane). Minimum penetration into the main member shall be 25 mm.
3. F_2 is loading perpendicular to the wall (out of the wall plane). Minimum penetration into the main member shall be 25 mm.
4. Uplift is calculated by taking the lowest of the withdrawal and pull-through load.
5. Shear values may be doubled if two fasteners are used. Uplift values must be multiplied by 0.75 if two fasteners are used.

| Model No. | Fastener Length (mm) | Thread Length (mm) | Main Member (SG8) | Characteristic Withdrawal Load, $R_{k,w}$ (N/mm) | Characteristic Pull-through Load, $R_{k,p}$ (N/mm) |
|-----------|----------------------|--------------------|---------------------------------|--|--|
| SDWC15450 | 114 | 108 | End Grain Single Stud (45mm) | 96 | 117 |
| SDWC15600 | 152 | 136 | Edge Single Joist/Rafter (45mm) | 166 | — |
| | | | Face Single Plate (45mm) | 139 | 133 |
| | | | Face Double Plate (80–90mm) | 147 | 164 |

1. Withdrawal is the capacity of the fastener tip pulling out of the main member.
2. Pull-through is the capacity of the head pulling through the side member.

Typical Roof-to-Wall Connection

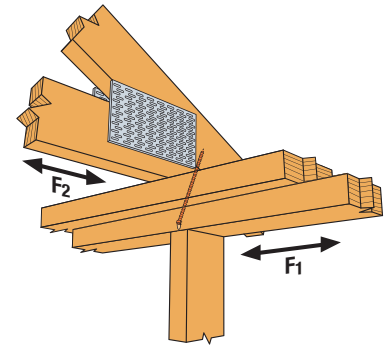

Typical single SDWC installation

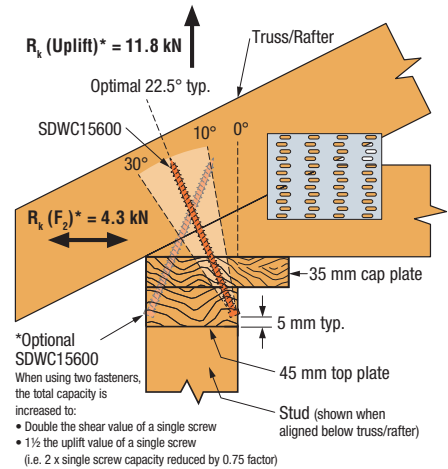

Uplift and Shear Capacity Truss/Rafter to Plate Condition (Optional second screw lighter shade)

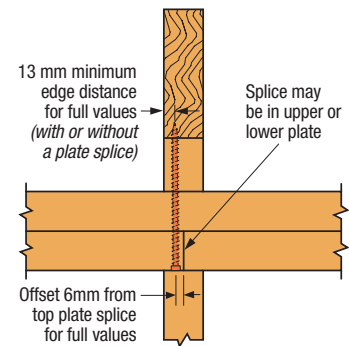

Min. edge distance for top plate splice

Stud-to-Plate Connections

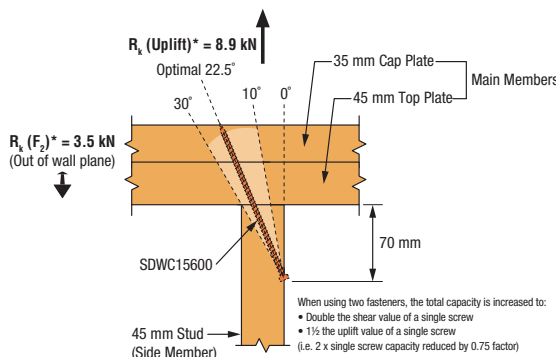

Stud-to-top plate condition
(This application requires SDWC15600)

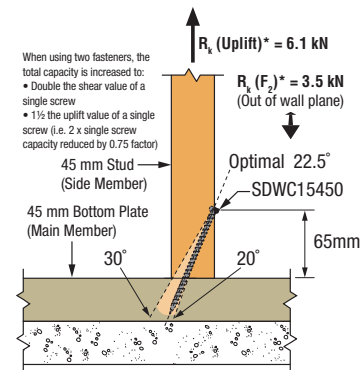

Stud-to-bottom plate condition over concrete/masonry foundation
(This application requires SDWC15450)

Structural Fasteners for Connecting Timber-To-Timber

Strong-Drive® SDWC TRUSS Screw Features

Orange colour for easy inspection of 152 mm screws

6-Lobe Drive reduces cam out, enabling easier driving

Fully-threaded shank engages the entire length of the fastener, providing a secure connection between the roof and wall framing members

Cap-style head countersinks fully into the double top plate to avoid interference with drywall or finish trades

E-Coat™ Black electrocoating for 114 mm screws

Type-17 point for faster starts and easier driving

Installation guide (included) to help ensure proper installation angle

- Wide tolerance on installation angle makes it easy to install the SDWC correctly
- Matched-tolerance driver bit (included) engages fastener head securely to allow one-handed driving (replacement bit part no. BIT30T-R1)
- Can be installed from inside the structure, eliminating exterior work on the upper stories and enhancing job safety
- Fastening can be performed before or after exterior sheathing is applied for added flexibility

Product and Packaging Information

| Fastener Model | Length (mm) | Finish | Bit Included | Guide Included | Fasteners Per Pack | Packs Per Carton | Model No. |
|----------------|-------------|--|--------------|----------------|--------------------|------------------|--------------|
| SDWC15600 | 152 | Clear Zinc Coating (with Orange Topcoat) | BIT30T | SDWC-GUIDE | 50 | 6 | SDWC15600-KT |
| SDWC15450 | 114 | E-Coat Black | BIT30T | SDWC-GUIDE275 | 50 | 6 | SDWC15450-KT |

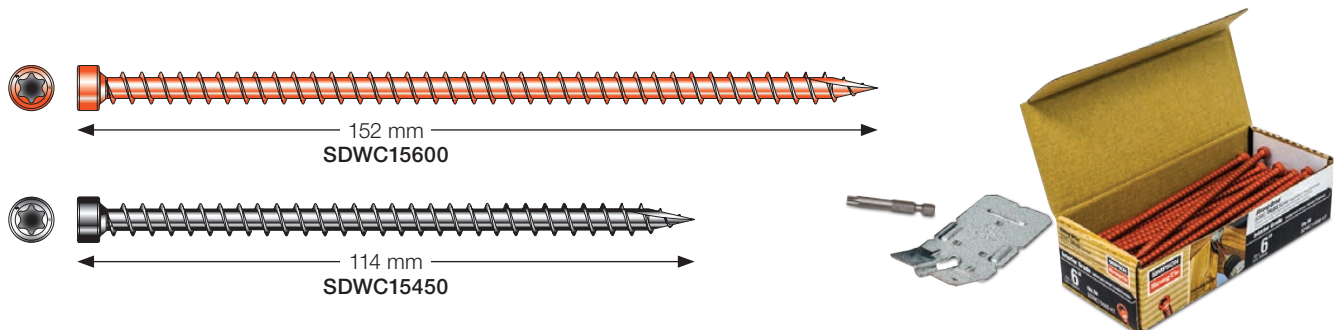

Structural Fasteners for Connecting Timber-To-Timber

Strong-Drive® SDWS TIMBER Screw

Designed to provide an easy-to-install, high-strength alternative to through-bolting and traditional lag screws.

The Strong-Drive® SDWS Timber screw also provides a method to fasten studs to top or bottom plates.

Material: Heat-treated carbon steel.

Finish: Double-barrier coating. See Corrosion Information.

The SDWS Timber Screws have a corrosion resistant coating and may be used where the fasteners are required to exhibit corrosion resistance when exposed to environmental conditions and preservative-treated timber, subject to some limitations.

Related Links For more information and drawings [click here to visit webpage](#)

Technical Data

| Model No. | Fastener Length (mm) | Effective Thread Length (mm) | Main Member (SG8) | Side Member (SG8) | Characteristic Load, R_k (kN) | |
|--------------|----------------------|------------------------------|--------------------|---------------------|---------------------------------|--|
| | | | | | Uplift | |
| SDWS22300DB | 76 | 31 | Single Stud (45mm) | Single Plate (45mm) | 2.3 | |
| | | | | Double Plate (80mm) | — | |
| SDWS22400DB | 102 | 57 | Single Stud (45mm) | Single Plate (45mm) | 5.0 | |
| | | | | Double Plate (80mm) | 1.9 | |
| SDWS22500DB | 127 | 70 | Single Stud (45mm) | Single Plate (45mm) | 10.1 | |
| | | | | Double Plate (80mm) | 6.8 | |
| SDWS22600DB | 152 | 70 | Single Stud (45mm) | Single Plate (45mm) | 10.1 | |
| | | | | Double Plate (80mm) | 10.1 | |
| SDWS22800DB | 203 | 70 | Single Stud (45mm) | Single Plate (45mm) | 10.1 | |
| | | | | Double Plate (90mm) | 10.1 | |
| SDWS221000DB | 254 | 70 | Single Stud (45mm) | Single Plate (45mm) | 10.1 | |
| | | | | Double Plate (90mm) | 10.1 | |

1. Main Member is the part where the fastener tip is embedded. Side Member is the part adjacent to the fastener head.
2. Uplift values may be doubled if two fasteners are used (spaced 50 mm apart).
3. Effective thread length is the amount of thread embedded into the Side Member, given the Main Member thickness.

| Model No. | Fastener Length (mm) | Total Thread Length (mm) | Characteristic Endgrain Withdrawal Load, $R_{k,w}$ (N/mm) | Maximum Endgrain Withdrawal Load, $R_{k,w}$ (kN) |
|--------------|----------------------|--------------------------|---|--|
| SDWS22300DB | 76 | 38 | 74 | 2.8 |
| SDWS22400DB | 102 | 60 | 88 | 5.3 |
| SDWS22500DB | 127 | 70 | 145 | 10.1 |
| SDWS22600DB | 152 | 70 | 145 | 10.1 |
| SDWS22800DB | 203 | 70 | 145 | 10.1 |
| SDWS221000DB | 254 | 70 | 145 | 10.1 |

Typical Roof-to-Wall Connection

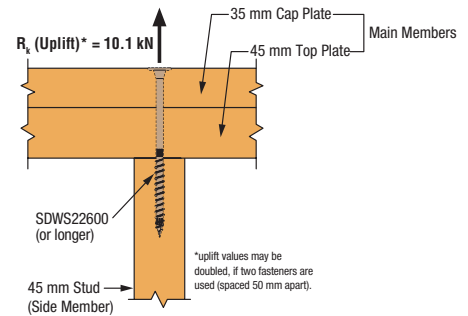

Uplift stud-to-top plate condition

Stud-to-Plate Connections

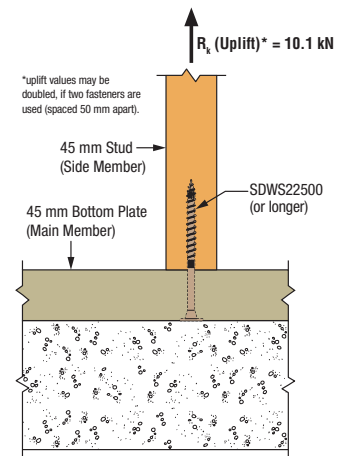

Uplift stud-to-bottom plate condition

Click here to download and refer to (C-C-AU16) catalogue page 95, for **SDWS characteristic shear capacities.**

Structural Fasteners for Connecting Timber-To-Timber

Strong-Drive® SDWS TIMBER Screw Features

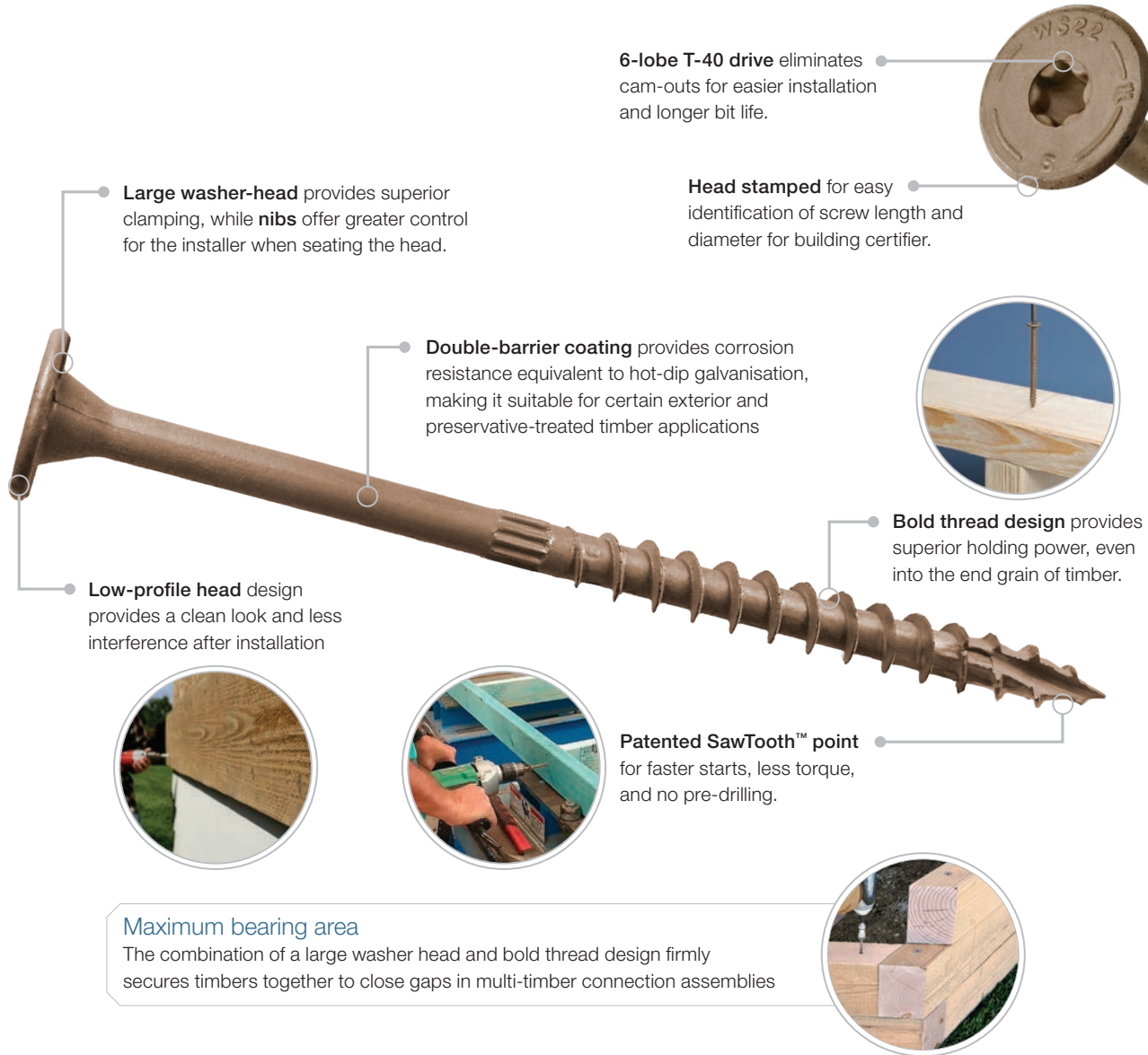

Product and Packaging Information

Bit(s) included with every box of screws

| Model No. | Dia. (mm) | Length (mm) | Thread Length (mm) | Point | Drive Size | Replacement Bit | | | | | | | | | | | | | | | | | | | | | | | | | | | | |
|---|------------------|--------------|--------------------|-------|------------------|-----------------|-------------|-----|------------------|-----------------|-------------|-----|------------------|-----------------|-------------|-----|------------------|-----------------|-------------|-----|------------------|-----------------|-------------|-----|------------------|------------------|--------------|--|-----|----------------------------------|------------------------|-----------|-------------|----------------|
| <table border="1"> <thead> <tr> <th>12 Pack</th> <th>50 Pack</th> <th>Bulk Pack</th> <th>Qty</th> </tr> </thead> <tbody> <tr> <td>SDWS22300DB-RC12</td> <td>SDWS22300DB-R50</td> <td>SDWS22300DB</td> <td>950</td> </tr> <tr> <td>SDWS22400DB-RC12</td> <td>SDWS22400DB-R50</td> <td>SDWS22400DB</td> <td>600</td> </tr> <tr> <td>SDWS22500DB-RC12</td> <td>SDWS22500DB-R50</td> <td>SDWS22500DB</td> <td>500</td> </tr> <tr> <td>SDWS22600DB-RC12</td> <td>SDWS22600DB-R50</td> <td>SDWS22600DB</td> <td>400</td> </tr> <tr> <td>SDWS22800DB-RC12</td> <td>SDWS22800DB-R50</td> <td>SDWS22800DB</td> <td>250</td> </tr> <tr> <td>SDWS221000DBRC12</td> <td>SDWS221000DB-R50</td> <td>SDWS221000DB</td> <td></td> </tr> </tbody> </table> | 12 Pack | 50 Pack | Bulk Pack | Qty | SDWS22300DB-RC12 | SDWS22300DB-R50 | SDWS22300DB | 950 | SDWS22400DB-RC12 | SDWS22400DB-R50 | SDWS22400DB | 600 | SDWS22500DB-RC12 | SDWS22500DB-R50 | SDWS22500DB | 500 | SDWS22600DB-RC12 | SDWS22600DB-R50 | SDWS22600DB | 400 | SDWS22800DB-RC12 | SDWS22800DB-R50 | SDWS22800DB | 250 | SDWS221000DBRC12 | SDWS221000DB-R50 | SDWS221000DB | | 5.6 | 75 100 125 150 200 250 | 38 60 70 70 70 | SawTooth™ | T-40 6-lobe | BIT40T-134-RC3 |
| 12 Pack | 50 Pack | Bulk Pack | Qty | | | | | | | | | | | | | | | | | | | | | | | | | | | | | | | |
| SDWS22300DB-RC12 | SDWS22300DB-R50 | SDWS22300DB | 950 | | | | | | | | | | | | | | | | | | | | | | | | | | | | | | | |
| SDWS22400DB-RC12 | SDWS22400DB-R50 | SDWS22400DB | 600 | | | | | | | | | | | | | | | | | | | | | | | | | | | | | | | |
| SDWS22500DB-RC12 | SDWS22500DB-R50 | SDWS22500DB | 500 | | | | | | | | | | | | | | | | | | | | | | | | | | | | | | | |
| SDWS22600DB-RC12 | SDWS22600DB-R50 | SDWS22600DB | 400 | | | | | | | | | | | | | | | | | | | | | | | | | | | | | | | |
| SDWS22800DB-RC12 | SDWS22800DB-R50 | SDWS22800DB | 250 | | | | | | | | | | | | | | | | | | | | | | | | | | | | | | | |
| SDWS221000DBRC12 | SDWS221000DB-R50 | SDWS221000DB | | | | | | | | | | | | | | | | | | | | | | | | | | | | | | | | |

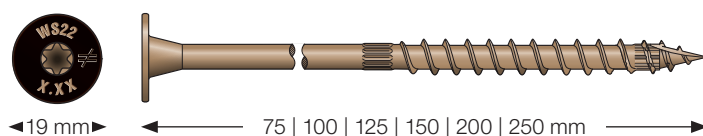

Outdoor Accents®

Related Links

For more information and drawings [click here to visit webpage](#)

Angles

Outdoor Accents angles tie together beams, rafters and more. These angles make structural connections between beams and posts stronger and provide consistent, strong corners for a variety of outdoor projects.

APA4: Heavy Angle (2 required).

APA21: Angle — Light Rafter Tie.

Material: APA4 – 2.7 mm thick; APA21 2 mm thick.

Finish: Galvanised ZMAX® coating with black powder coating.
See Corrosion Information.

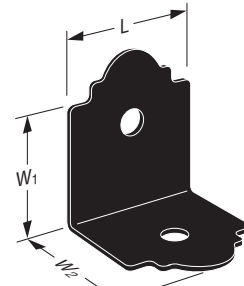

APA4

Technical Data

| Model No. | Dimensions (mm) | | | Fastener Qty | | Characteristic Load, R _k (kN) | |
|--------------------|-----------------|----------------|----------------|--------------|------|--|----------------|
| | Length | W ₁ | W ₂ | Column | Beam | Uplift | F ₁ |
| APA4 ¹ | 76 | 83 | 76 | 2 | 2 | 7.2 | 14.4 |
| APA21 ² | 35 | 51 | 38 | 1 | 1 | 2.5 | 4.7 |

- Values are for two angles and must be installed in pairs.
- Double angles to achieve 2x load

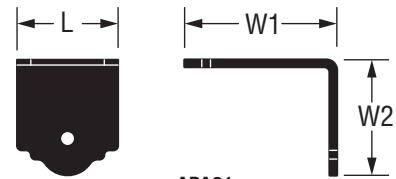

APA21

Post Bases

Outdoor Accents post bases secure wood columns to concrete, while providing a 25 mm standoff height that meets building code requirements and helps reduce decay. These bases accommodate 90 mm and 140 mm timber.

Finish: Galvanised ZMAX® Coating with black powder coating.
See Corrosion Information.

| Model No. | Material (mm) | |
|-----------|----------------|-----------------------|
| | Base Thickness | Knife Plate Thickness |
| APB44 | 1.6 | 2.7 |
| APB66 | 2.7 | 2.7 |

Technical Data

| Model No. | Dimensions (mm) | | | Fastener Qty | | Characteristic Load, R _k (kN) | |
|-----------|-----------------|-------|--------|--------------|------------------|--|----------|
| | Length | Width | Height | Column | Anchor Dia. (mm) | Uplift | Download |
| APB44 | 76 | 90 | 178 | 4 | 16 | 7.4 | 70.8 |
| APB66 | 127 | 140 | 191 | 4 | 16 | 12.6 | 153 |

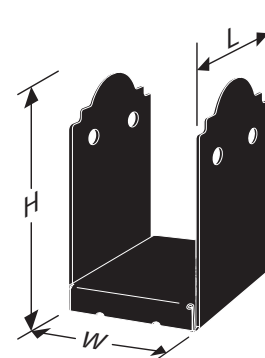

APB66

Outdoor Accents® (cont.)

Beam-to-Column Strap Ties

The flat T and L strap ties bring decorative flair and lateral strength to your outdoor living space or even an indoor project. They provide reinforcement for connections where one timber piece intersects another at a 90-degree angle. They're designed to accommodate multiple timber sizes and to be installed with Outdoor Accents structural timber screws and hex-head washers.

Material: 2.7 mm thick.

Finish: Galvanised ZMAX® coating with black powder coating.
See Corrosion Information.

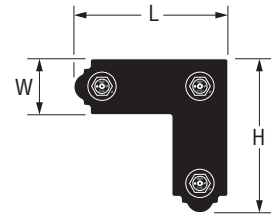

APL4
(Others similar)

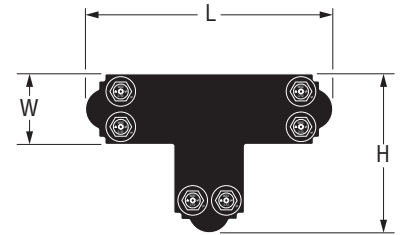







APT6
(Others similar)

Technical Data

| Model No. | Dimensions (mm) | | | Fastener Qty | | Characteristic Load, R _k (kN) | |
|-----------|-----------------|-------|--------|--------------|------|--|----------------|
| | Length | Width | Height | Column | Beam | Uplift | F ₁ |
| APL4 | 76 | 210 | 210 | 2 | 4 | 14.4 | 9.2 |
| APL6 | 127 | 286 | 286 | 4 | 6 | 21.0 | 21.6 |
| APT4 | 76 | 343 | 210 | 2 | 4 | 16.0 | 14.3 |
| APT6 | 127 | 445 | 286 | 4 | 8 | 24.2 | 17.8 |











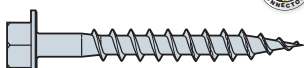

1. Values are for two ties and must be installed in pairs.

Fasteners available for Outdoor Accents®

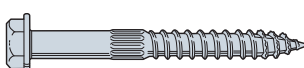
| Image | Model Number | Dimensions | Description | Finish | ≈ Box Qty |
|---|-------------------|---------------|--|--|-----------|
| Outdoor Accents | | | | | |
| Connector Screw | | | | | |
|  | SD10112DBBR50 | #10 x 38mm | Connector screw, 1/4" Hex head, Patented serrated threads, Sharp point |  Double-barrier Coating | 50 |
| Structural Wood Screw | | | | | |
|  | SDWS22312DBBRC12 | 5.6 x 89mm | Ribbed large washer head |  Double-barrier Coating | 12 |
| | SDWS22312DBB-R50 | 5.6 x 89mm | Patented SawTooth™ point | | 50 |
| | SDWS22512DBB-RC12 | 5.6 x 140mm | T-40 6-lobe drive | | 12 |
| Hex-Head Washer | | | | | |
|  | STN22-R8 | 38mm diameter | Hex-head washer |  Quik Guard® black coating for exterior use with a black powder-coat finish | 8 |

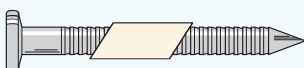
 These coated fasteners possess a level of corrosion resistance that makes them suitable for use in some exterior and corrosive environments and with some preservative-treated timber. For applications in higher-exposure applications, consider Type-316 stainless-steel fasteners for superior corrosion resistance. See www.strongtie.co.nz for additional important information before selecting a fastener for a specific application.

Fasteners available for connectors

| Image | Model Number | Dimensions | Description | Finish | ≈ Box Qty |
|---|----------------|---------------|--|---|-----------|
| Strong-Drive® SCNR RING-SHANK CONNECTOR Nail | | | | | |
|  | SSNA8D | 38mm x 3.32mm | Full round-smooth head, Annular-Ring Shank, Diamond point |  | 147 |
| | SSNA8D5 | | | | 735 |
| | SSNA10D | 38mm x 3.75mm | | | 126 |
| | SSNA10D5 | | | | 630 |
| | SSA10DD | 75mm x 3.75mm | | | 66 |
| | SSA10D5 | | | | 330 |
| Strong-Drive® SCN SMOOTH-SHANK CONNECTOR Nail | | | | | |
|  | N8DHDG-R | 38mm x 3.32mm | Full round-smooth head, Smooth Shank, Diamond point |  | 147 |
| | N8D5HDG-R | | | | 735 |
| | N10DHDG-R | 38mm x 3.75mm | | | 120 |
| | N10D5HDG-R | | | | 600 |
| | 10D5HDG-R | 75mm x 3.75mm | | | 250 |
| Strong-Drive® SD CONNECTOR Screw | | | | | |
|  | SD9112R100 | #9 x 38mm | 1/4" Hex head Patented serrated threads, Sharp point |  | 100 |
| | SD9212R100-R | #9 x 64mm | | | 100 |
| | SD10112R100 | #10 x 38mm | | | 100 |
| | SD10212R100 | #10 x 64mm | | | 100 |
| Strong-Drive® SDS HEAVY-DUTY CONNECTOR Screw | | | | | |
|  | SDS25112SS-R25 | 6.4mm x 38mm | 3/8" Hex Head Serrated threads, Type 17 point |  | 25 |
| | SDS25212SS-R25 | 6.4mm x 64mm | | | 25 |
| | SDS25300SS-R25 | 6.4mm x 76mm | | | 25 |
| | SDS25112-R25 | 6.4mm x 38mm | | | 25 |
| | SDS25212-R25 | 6.4mm x 64mm | | | 25 |
| | SDS25300-R25 | 6.4mm x 76mm | | | 25 |
| Collated Strong-Drive® 33° SCNR RING-SHANK CONNECTOR Nail* | | | | | |
|  | T10A150MCN | 38mm x 3.32mm | Full round-smooth head, Annular-Ring Shank, Diamond point 22 nails per paper-collated strips |  | 1,500 |
| | T9A150MCN | 38mm x 3.75mm | | | 1,500 |
| | T9A250MCN | 64mm x 3.75mm | | | 1,000 |
| Collated Strong-Drive® 33° SCN SMOOTH-SHANK CONNECTOR Nail* | | | | | |
|  | N8HDGPT500 | 38mm x 3.32mm | Full round-smooth head, Smooth Shank, Diamond point 22 nails per paper-collated strips |  | 500 |
| | N8HDGPT4000 | | | | 4,000 |
| | N10HDGPT500 | 38mm x 3.75mm | | | 500 |
| | N10HDGPT3000 | | | | 3,000 |
| | N10DHDGPT500 | 64mm x 3.75mm | | | 500 |
| | N10DHDGPT2500 | | | | 2,500 |

 These coated fasteners possess a level of corrosion resistance that makes them suitable for use in some exterior and corrosive environments and with some preservative-treated timber. For applications in higher-exposure applications, consider Type-316 stainless-steel fasteners for superior corrosion resistance. See www.strongtie.co.nz for additional important information before selecting a fastener for a specific application.

*Compatible Pneumatic Tools: Simpson Strong-Tie CCN64 Collated Connector Nailer (Drives both 38 mm and 64 mm collated nails); Suitable for use with pneumatic tools that can use 33° paper strip collated nails and suitable diameter and length — always refer pneumatic tool manufacturer specifications for fastener suitability.



Every day we work hard to earn your business, blending the talents of our people with the quality of our products and services to exceed your expectations. This is our pledge to you.

Simpson Strong-Tie® (New Zealand) Limited

GST: 106789002

strongtie.co.nz

52A Arrenway Drive
Albany, Auckland 0632
New Zealand

+64 9 477 4440

+64 9 475 9724 Fax